

B200(XL)-ODL

# HOLIDAY AT HOME

Technische informatie  
Technical information  
Informations techniques  
Technische Daten



OUTDOOR LIVING by  
**BRUSTOR**®

[www.brustor.com](http://www.brustor.com)  
V2016.00

Doorsnedes  
 Cross-sections  
 Sections  
 Durchschnitte

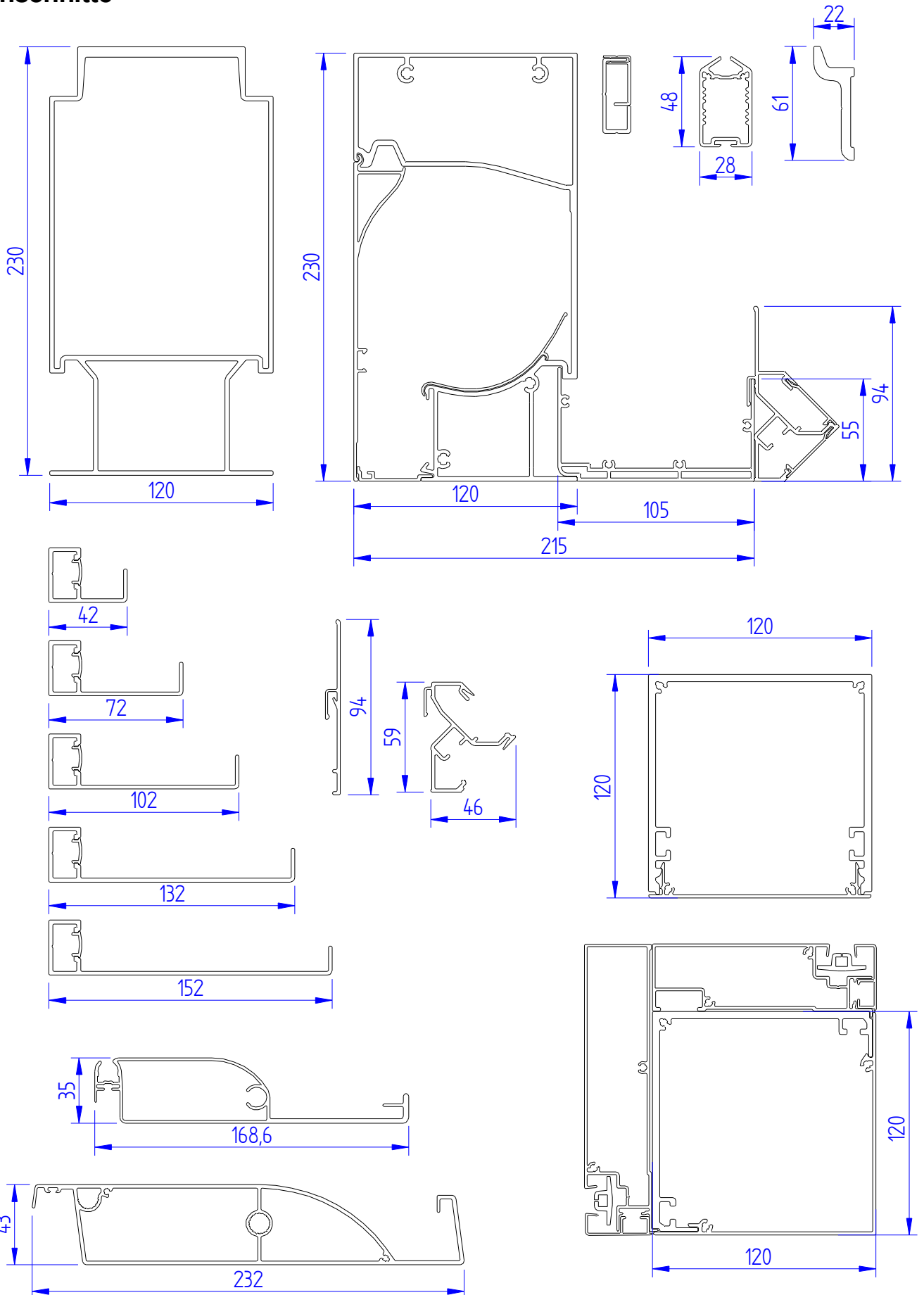

**Grondbevestiging**  
**groundfixation**  
**Fixation au sol**  
**Grundbefestigung**

Pole support (std)  
 Support de poteau (std)  
 Pfostenstutz (std)

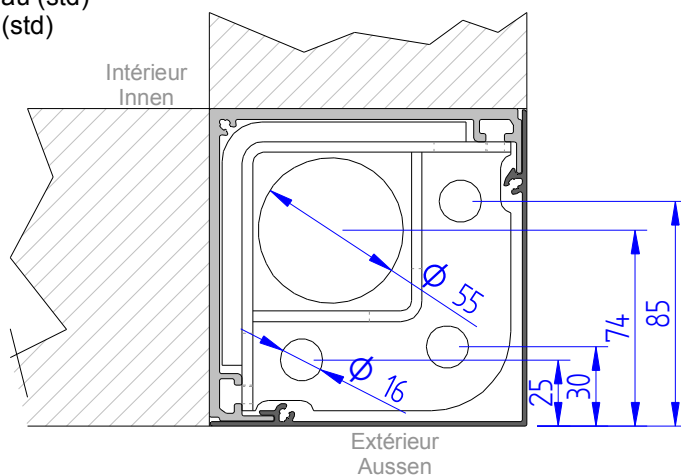
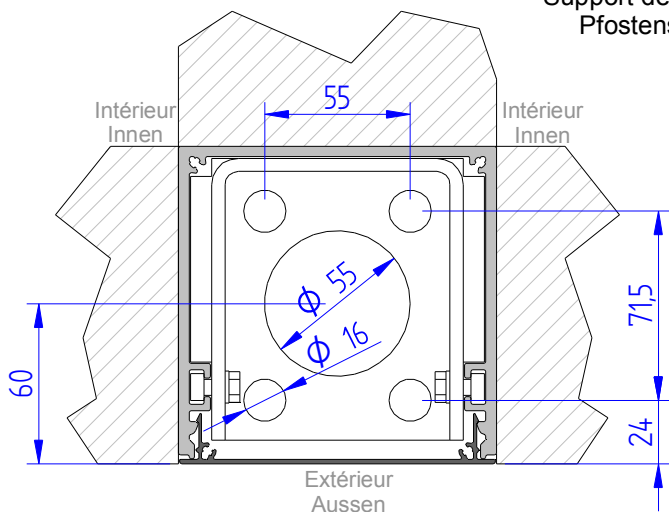

Grondanker  
 Ground anchor  
 Pied fixe à enterrer  
 Grundanker

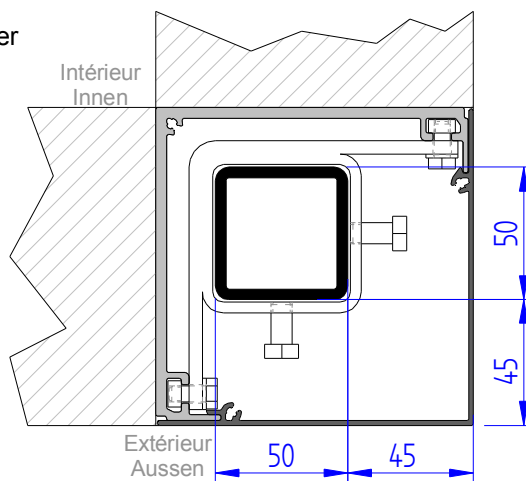
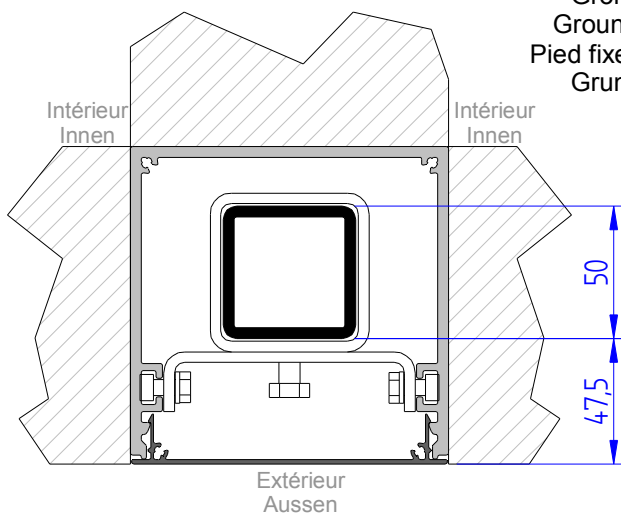

Vloerplaat 20x20cm  
 Floorplate 20x20cm  
 Plaque de sol 20x20cm  
 Bodenplatte 20x20cm

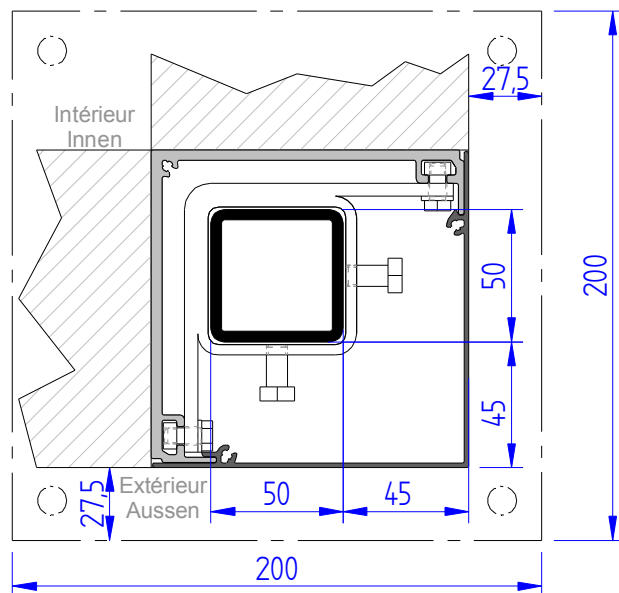
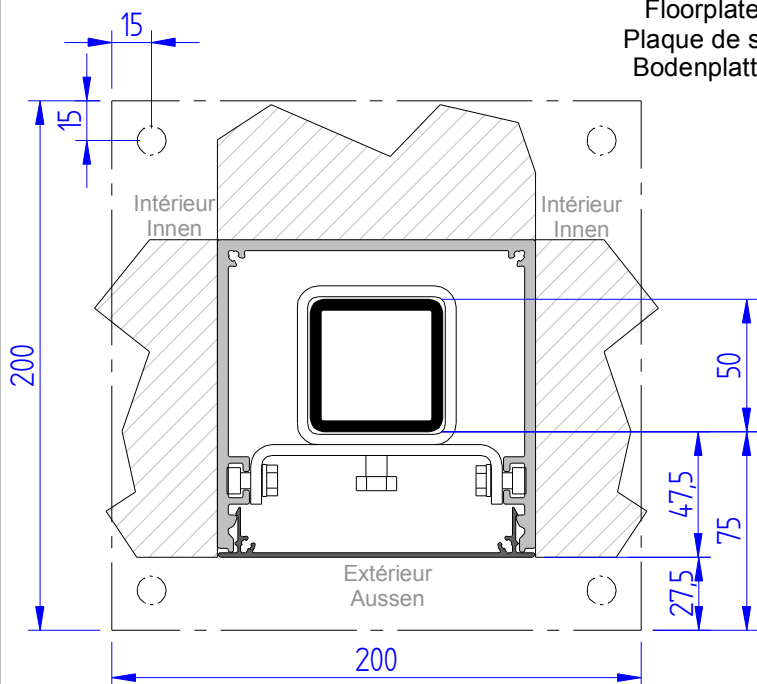

**Muurbevestiging**  
**Wall fixation**  
**Fixation murale**  
**Fassadenmontage**

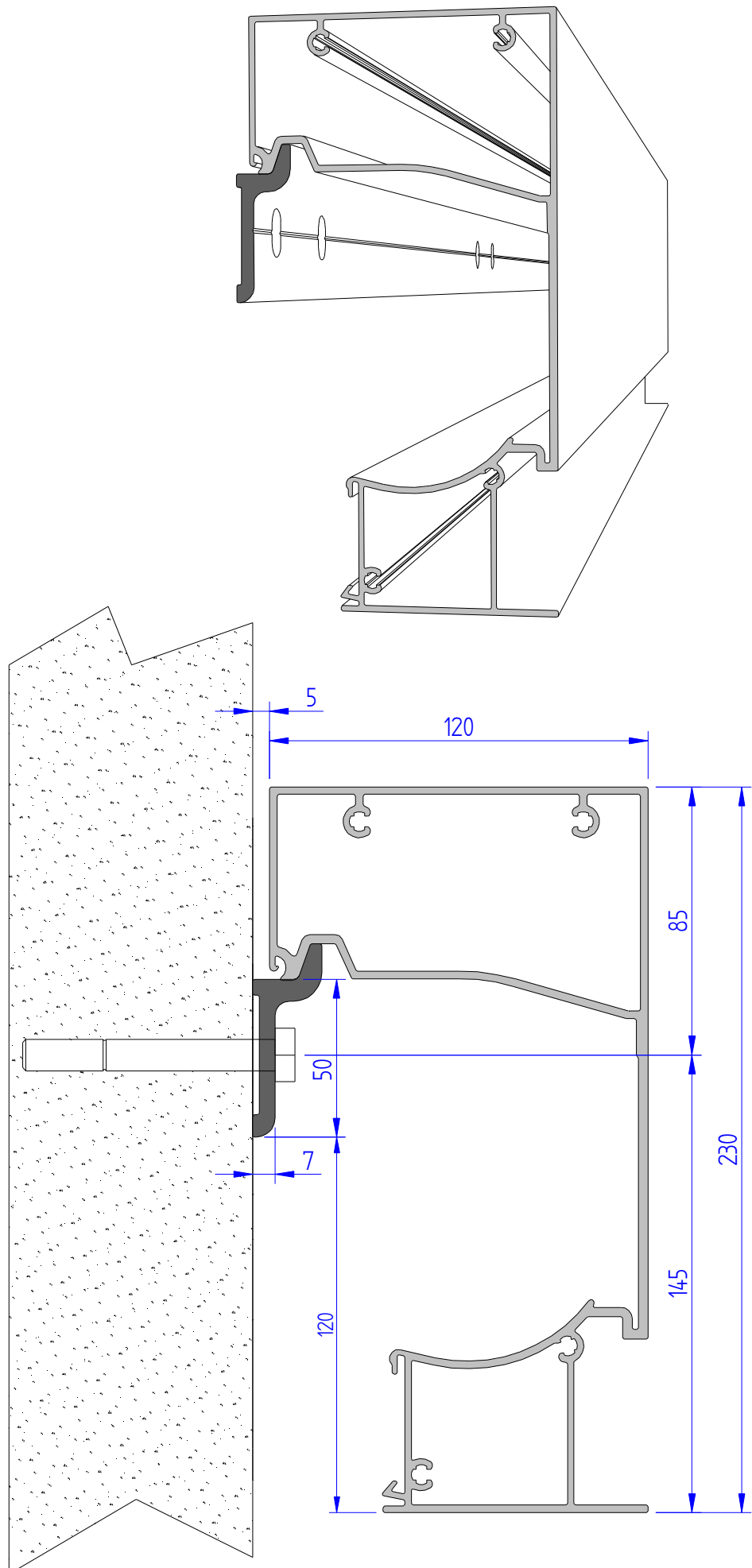

**Hoekstukken**  
**Corner pieces**  
**Pièces cornières**  
**Winkel**

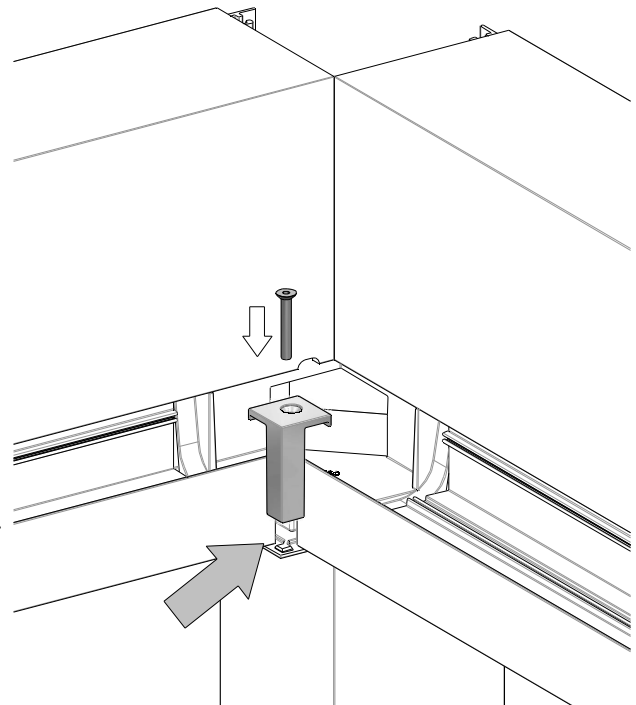
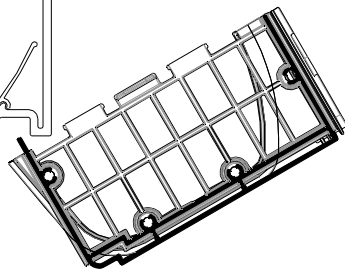
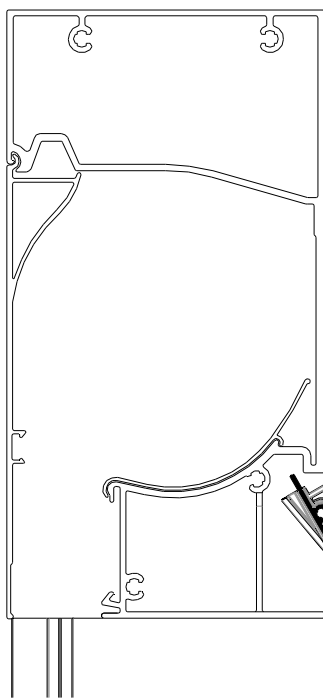
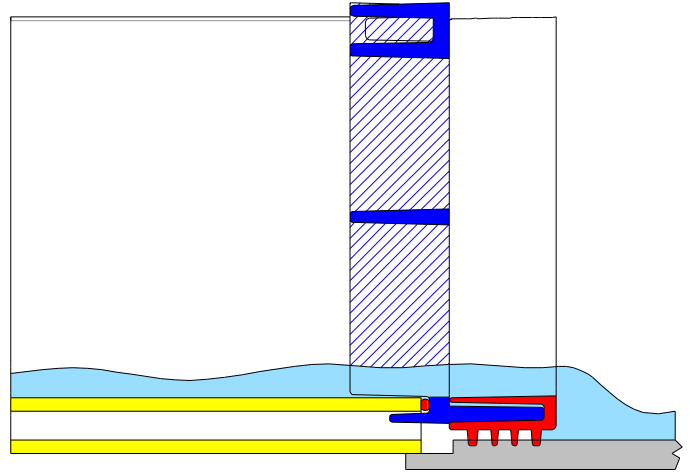
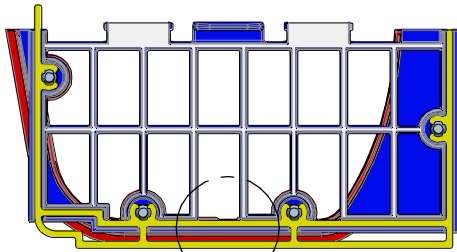
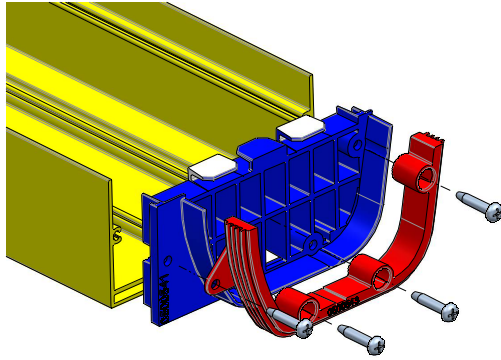
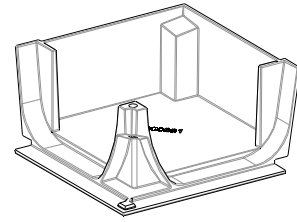
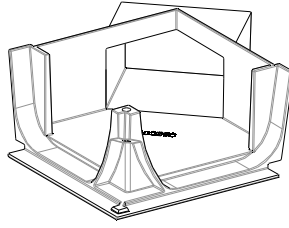

Lamellen open 90°  
Louvres open 90°  
Lames ouvertes 90°  
Lamellen offen 90°

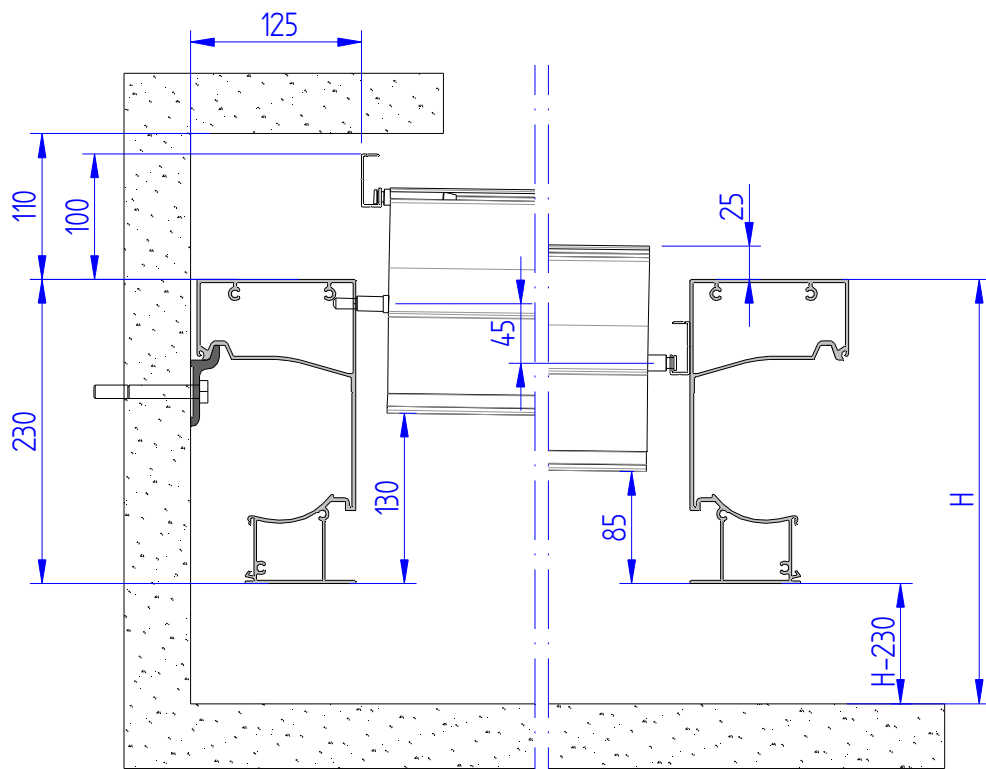

B200

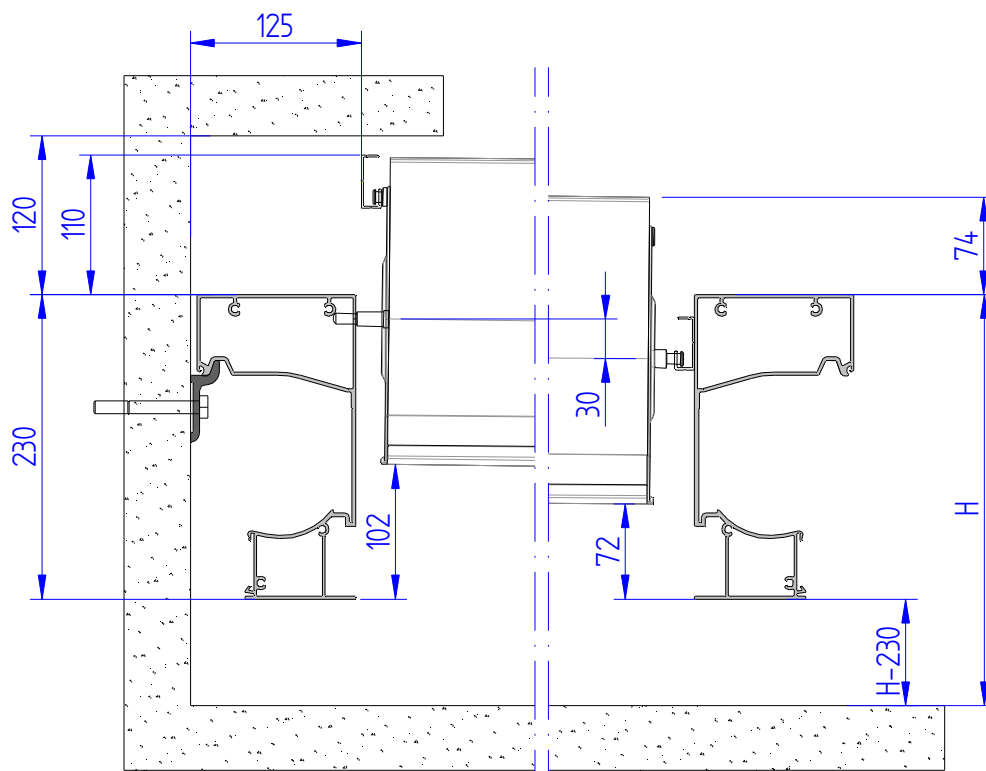

B200XL

Gewicht (kg)  
 Weight (kg)  
 Poids (kg)  
 Gewicht (kg)

L	B	2000	2200	2400	2600	2800	3000	3200	3400	3600	3800	4000	4200	4400	4600	4800	5000	5200	5400	5600	5800	6000	6200	6400	6600	6800	7000
		2680	250	260	280	290	300	310	320	330	340	350	360	370	390	400	410	420	440	450	460	470	490	500	510	520	530
2840	260	270	290	300	310	320	330	340	350	360	380	390	400	410	430	440	450	470	480	490	500	520	530	540	550	570	580
3000	270	280	290	310	320	330	350	360	370	390	400	410	430	440	450	470	480	500	510	520	540	550	560	580	590	600	620
3160	280	290	300	320	330	350	360	370	390	400	410	430	440	460	470	480	500	510	530	540	550	570	580	600	610	620	640
3320	280	300	310	330	340	360	370	380	400	410	430	440	460	470	490	500	520	530	540	560	570	590	600	620	630	650	660
3480	290	310	320	340	350	370	380	400	410	430	440	460	470	490	500	520	530	550	560	580	590	610	620	640	650	670	690
3640	300	320	330	350	360	380	390	410	420	440	460	470	490	500	520	530	550	560	580	600	610	630	640	660	670	690	710
3800	310	320	340	360	370	390	400	420	440	450	470	480	500	520	530	550	570	580	600	620	630	650	660	680	690	710	730
3960	320	330	350	370	380	400	420	430	450	470	480	500	520	530	550	570	580	600	620	630	650	670	680	700	720	730	750
4120	320	340	360	380	390	410	430	440	460	480	490	510	530	540	560	580	600	620	630	650	670	680	700	720	740	750	770
4280	330	350	370	380	400	420	440	460	470	490	510	530	540	560	580	600	620	630	650	670	690	710	720	740	760	770	790
4440	340	360	380	390	410	430	450	470	490	500	520	540	550	570	590	610	630	650	670	690	710	720	740	760	780	800	820
4600	350	370	390	400	420	440	460	480	490	510	530	550	570	590	610	630	650	670	690	710	720	740	760	780	800	820	840
4760	360	370	390	410	430	450	470	490	510	520	540	550	570	590	610	630	650	670	690	710	720	740	760	780	800	820	840
4920	360	380	400	420	440	460	480	500	520	540	560	580	600	620	640	660	680	700	720	740	760	780	800	820	840	860	880
5080	370	390	410	430	450	470	490	510	540	560	580	600	620	640	660	680	700	720	740	760	780	800	820	840	860	880	900
5240	380	400	420	440	460	480	510	530	550	570	590	610	630	650	670	690	720	740	760	780	800	820	840	860	880	900	930
5400	390	410	430	450	470	500	520	540	560	580	600	620	640	660	680	710	730	750	780	800	820	840	860	880	900	930	950
5560	400	420	440	460	480	510	530	550	570	590	620	640	660	680	700	730	750	770	790	820	840	860	880	900	930	950	970
5720	400	430	450	470	490	520	540	560	580	610	630	650	670	690	710	740	770	790	810	830	860	880	900	920	950	970	990
5880	410	430	460	480	500	530	550	570	600	620	640	670	690	710	740	760	780	810	830	850	870	900	920	940	970	990	1010
6040	420	440	470	490	510	540	560	590	610	630	660	680	700	730	750	780	800	820	850	870	890	920	940	960	990	1010	1030
6200	430	450	480	500	520	550	570	600	620	650	670	690	720	740	770	790	820	840	860	890	910	940	960	990	1010	1030	1060
6360	440	460	480	510	530	560	580	610	630	660	680	710	730	760	780	810	830	860	880	910	930	960	980	1010	1030	1060	1080
6520	440	470	490	520	540	570	600	620	650	670	700	720	750	770	800	820	850	870	900	920	950	980	1000	1030	1050	1080	1100
6680	450	480	500	530	550	580	610	630	660	680	710	740	760	790	810	840	870	890	920	940	970	1000	1020	1050	1070	1100	1120
6840	460	490	510	540	570	590	620	640	670	700	720	750	780	800	830	860	880	910	940	960	990	1010	1040	1070	1090	1120	1140
7000	470	490	520	550	580	600	630	660	680	710	740	760	790	820	850	870	900	930	950	980	1010	1030	1060	1090	1110	1140	1160

Screen = + 5kg/m

**B200XL = + 3kg/m<sup>2</sup>**

**Openingsrichting van de lamellen**  
**Opening direction of the louvres**  
**Sens d'ouverture des lames**  
**Öffnungsrichtung der Lamellen**

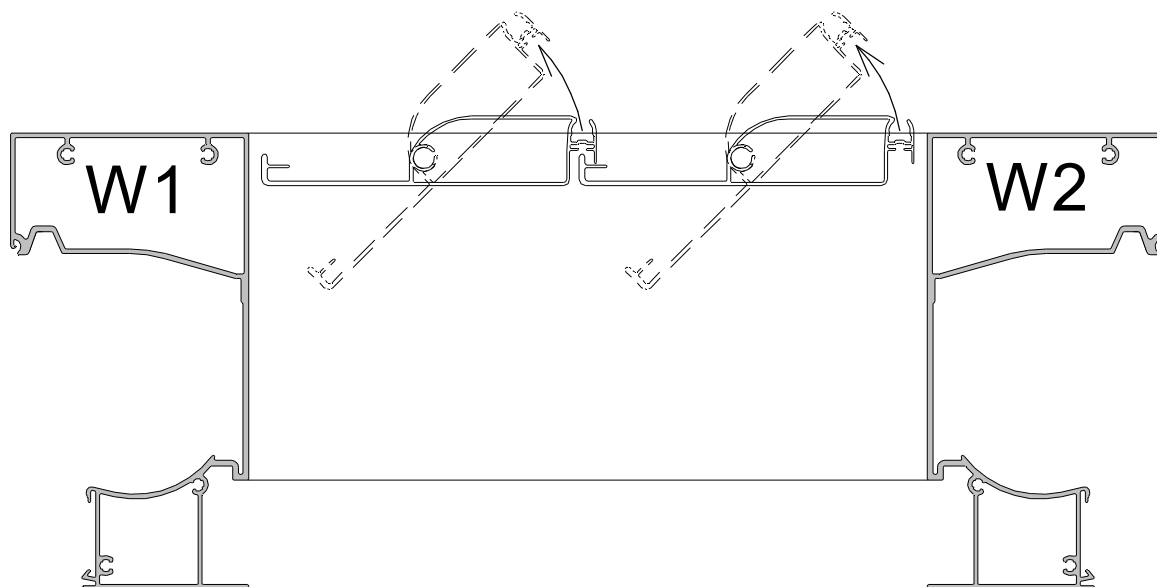



**Opvulprofielen**  
**Fixed profiles**  
**Profils de rattrapage / Lames Fixes**  
**Feste Profile**

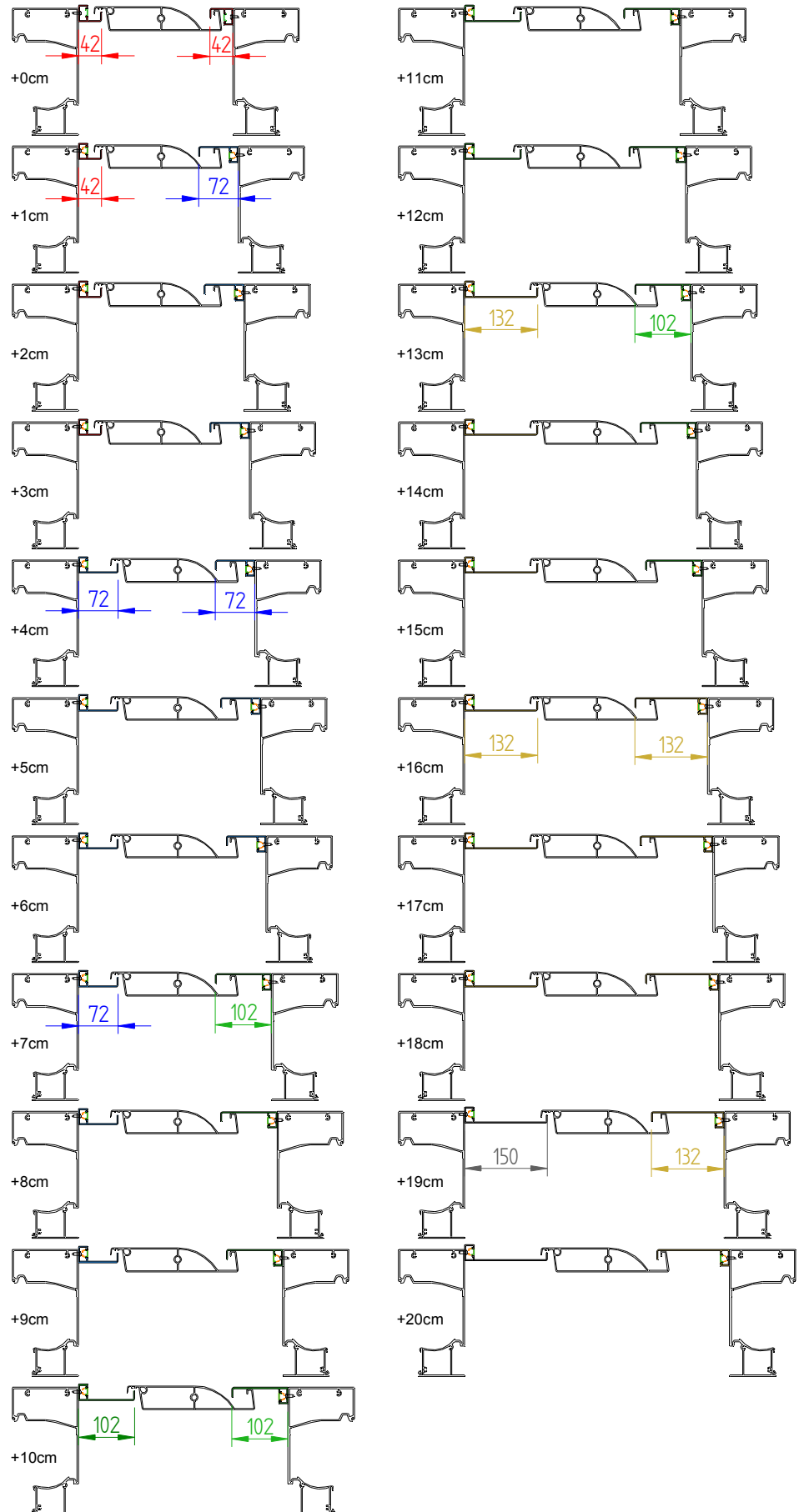
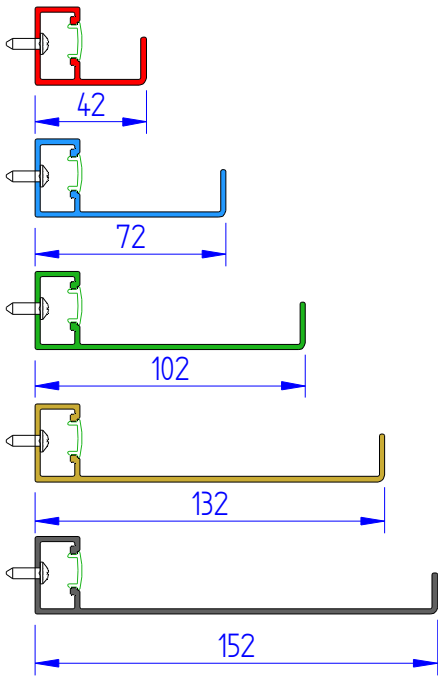

# Asjes van de lamellen

## Louvre axes

## Les axes des lames

## Lamellenwellen

0400460 

0300188 

0400461 

0300181 

	Vlak	LED
0400460	x	x
0300188	x	
0400461		x
0300181	x	x

0400387 

KOPPELLIGGER 

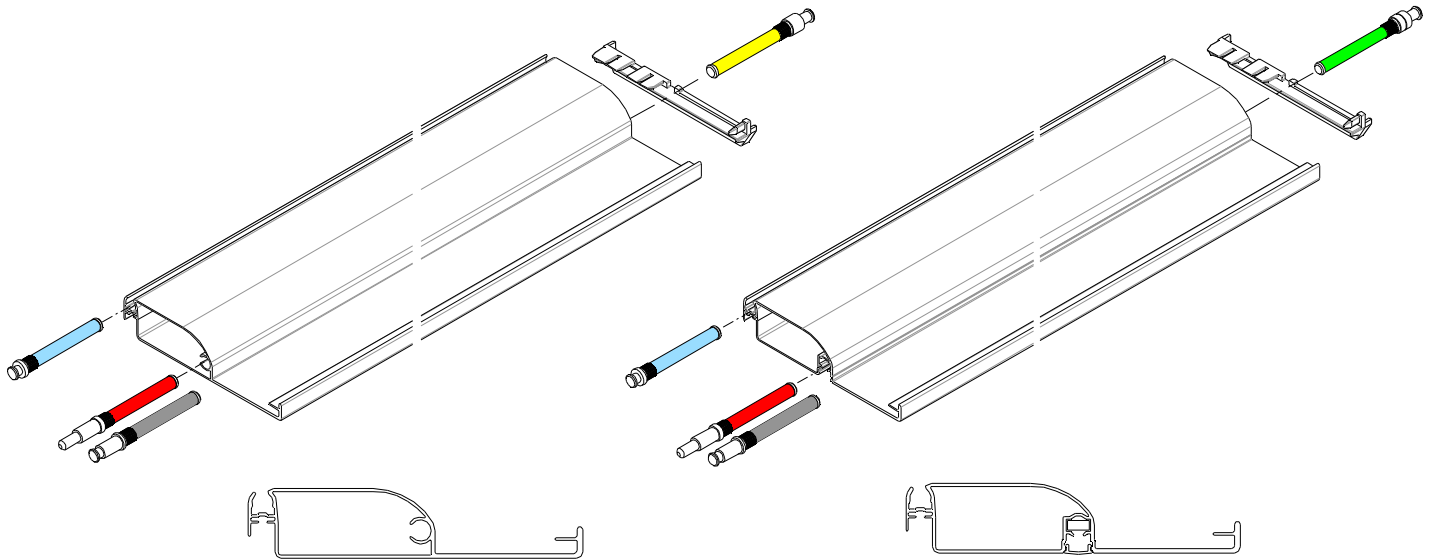

	Vlak	LED
0400460	x	x
0300188	x	
0400461		x
0300181	x	x

0400460 

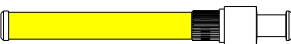
0300188 

0400461 

0300181 

0400387 

KOPPELLIGGER 

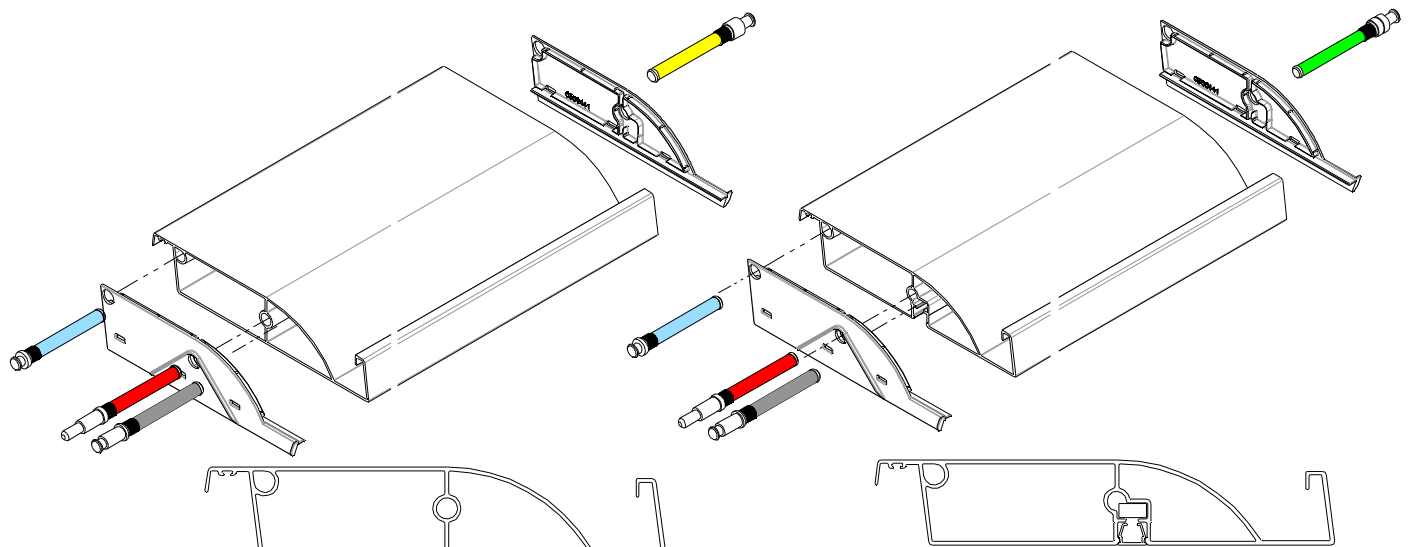

# Lamellen  
 # Louvres  
 # lames  
 # Lamellen

OL- B200								
SINGLE SIMPLE			KOPPELTYPE W COUPLE TYPE W L+R / G+D			KOPPEL TYPE W COUPLE TYPE W Midden/Milieu		
L		#	L		#	L		#
1270	1420	6	1210	1360	6	1150	1300	6
1430	1580	7	1370	1520	7	1310	1460	7
1590	1740	8	1530	1680	8	1470	1620	8
1750	1900	9	1690	1840	9	1630	1780	9
1910	2060	10	1850	2000	10	1790	1940	10
2070	2220	11	2010	2160	11	1950	2100	11
2230	2380	12	2170	2320	12	2110	2260	12
2390	2540	13	2330	2480	13	2270	2420	13
2550	2700	14	2490	2640	14	2430	2580	14
2710	2860	15	2650	2800	15	2590	2740	15
2870	3020	16	2810	2960	16	2750	2900	16
3030	3180	17	2970	3120	17	2910	3060	17
3190	3340	18	3130	3280	18	3070	3220	18
3350	3500	19	3290	3440	19	3230	3380	19
3510	3660	20	3450	3600	20	3390	3540	20
3670	3820	21	3610	3760	21	3550	3700	21
3830	3980	22	3770	3920	22	3710	3860	22
3990	4140	23	3930	4080	23	3870	4020	23
4150	4300	24	4090	4240	24	4030	4180	24
4310	4460	25	4250	4400	25	4190	4340	25
4470	4620	26	4410	4560	26	4350	4500	26
4630	4780	27	4570	4720	27	4510	4660	27
4790	4940	28	4730	4880	28	4670	4820	28
4950	5100	29	4890	5040	29	4830	4980	29
5110	5260	30	5050	5200	30	4990	5140	30
5270	5420	31	5210	5360	31	5150	5300	31
5430	5580	32	5370	5520	32	5310	5460	32
5590	5740	33	5530	5680	33	5470	5620	33
5750	5900	34	5690	5840	34	5630	5780	34
5910	6060	35	5850	6000	35	5790	5940	35
6070	6220	36	6010	6160	36	5950	6100	36
6230	6380	37	6170	6320	37	6110	6260	37
6390	6540	38	6330	6480	38	6270	6420	38
6550	6700	39	6490	6640	39	6430	6580	39
6710	6860	40	6650	6800	40	6590	6740	40
6870	7000	41	6810	6900	41	6750	6800	41

OL- B200XL								
SINGLE SIMPLE			KOPPELTYPE W COUPLE TYPE W L+R / G+D			KOPPEL TYPE W COUPLE TYPE W Midden/Milieu		
L		#	L		#	L		#
1570	1770	6	1510	1710	6	1450	1650	6
1780	1980	7	1720	1920	7	1660	1860	7
1990	2190	8	1930	2130	8	1870	2070	8
2200	2400	9	2140	2340	9	2080	2280	9
2410	2610	10	2350	2550	10	2290	2490	10
2620	2820	11	2560	2760	11	2500	2700	11
2830	3030	12	2770	2970	12	2710	2910	12
3040	3240	13	2980	3180	13	2920	3120	13
3250	3450	14	3190	3390	14	3130	3330	14
3460	3660	15	3400	3600	15	3340	3540	15
3670	3870	16	3610	3810	16	3550	3750	16
3880	4080	17	3820	4020	17	3760	3960	17
4090	4290	18	4030	4230	18	3970	4170	18
4300	4500	19	4240	4440	19	4180	4380	19
4510	4710	20	4450	4650	20	4390	4590	20
4720	4920	21	4660	4860	21	4600	4800	21
4930	5130	22	4870	5070	22	4810	5010	22
5140	5340	23	5080	5280	23	5020	5220	23
5350	5550	24	5290	5490	24	5230	5430	24
5560	5760	25	5500	5700	25	5440	5640	25
5770	5970	26	5710	5910	26	5650	5850	26
5980	6180	27	5920	6120	27	5860	6060	27
6190	6390	28	6130	6330	28	6070	6270	28
6400	6600	29	6340	6540	29	6280	6480	29
6610	6810	30	6550	6750	30	6490	6690	30
6820	7000	31	6760	6900	31	6700	6800	31

**Domoticasysteem**  
**Home automation system**  
**Système domotique**  
**Automatisierung**

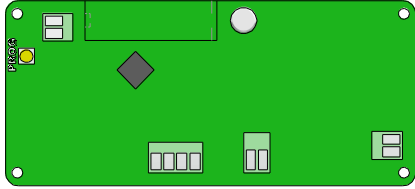

Lamellen  
 Louvres  
 Lames  
 Lamellen



Screen Altus



Screen LT

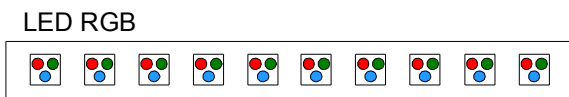
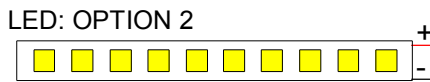
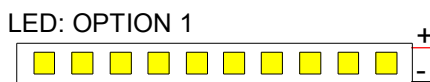
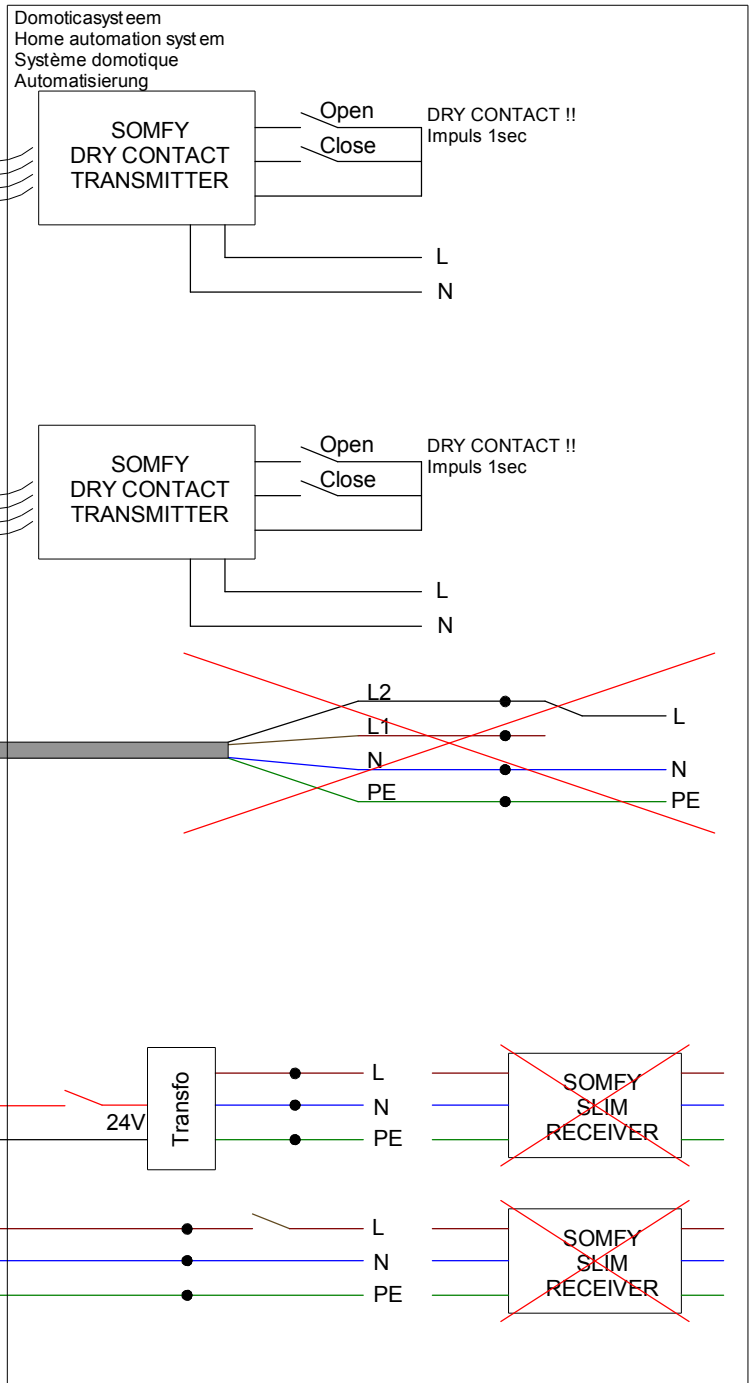

Niet mogelijk  
 Not possible  
 Pas possible  
 Nicht möglich

**Technische specificaties**  
**Technical specs**  
**Spécifications techniques**  
**Technische Data**

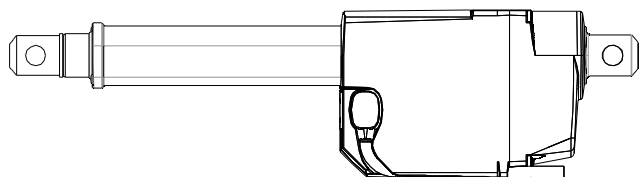

Lamellen  
 Louvres  
 Lames  
 Lamellen

- 100 Watt
- 24 V-DC
- 1800 N
- IP66
- 160 mm (slag/stroke/course)
- 10m (kabel/cable/câble/Kabel)

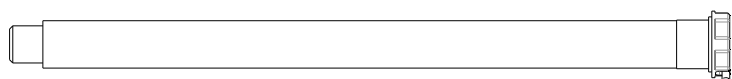

Screen

- 250 Watt
- 240 V-AC
- 15 Nm
- 17 rot/min
- IP44
- 10m (kabel/cable/câble/Kabel)

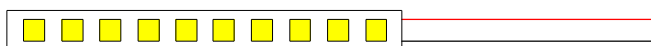

LED (wit)  
 LED (white)  
 LED (blanc)  
 LED (weiss)

- 5 Watt/m
- 24V-DC
- 3500 K
- 330 l/m
- 10m (kabel/cable/câble)



LED (RGB)

- 8 Watt/m
- 24 V-DC
- 10m (kabel/cable/câble/Kabel)

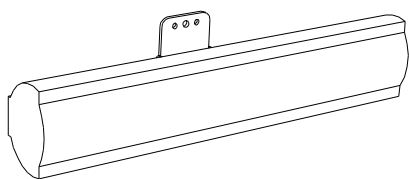

Verwarming  
 Heater  
 Chauffage  
 Heizung

- 2000 Watt
- 240 V-AC
- IP65
- 3m (kabel/cable/câble/Kabel)

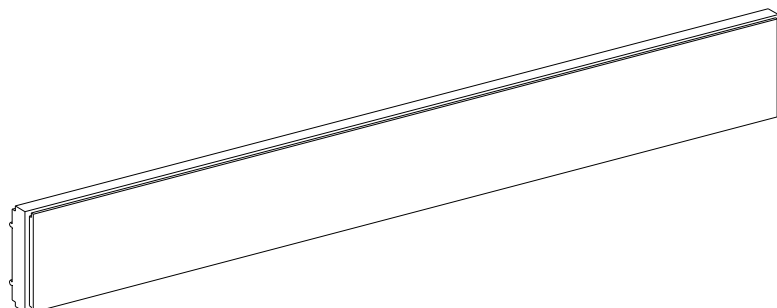

Heatstrip

- 2400 Watt (350°C!)
- 240 V-AC
- IPX5
- 1,6m (kabel/cable/câble/Kabel)
- 1364x165x48 / 8kg

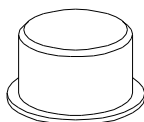

LED-SPOT

- 4,5 Watt
- 24 V-DC
- 3000K
- 380lm
- 10m (kabel/cable/câble/Kabel)
- IP54
- D52 x 28mm

**Oversteek deurpaal**  
**Décalage profil de porte**  
**Offset door profile**

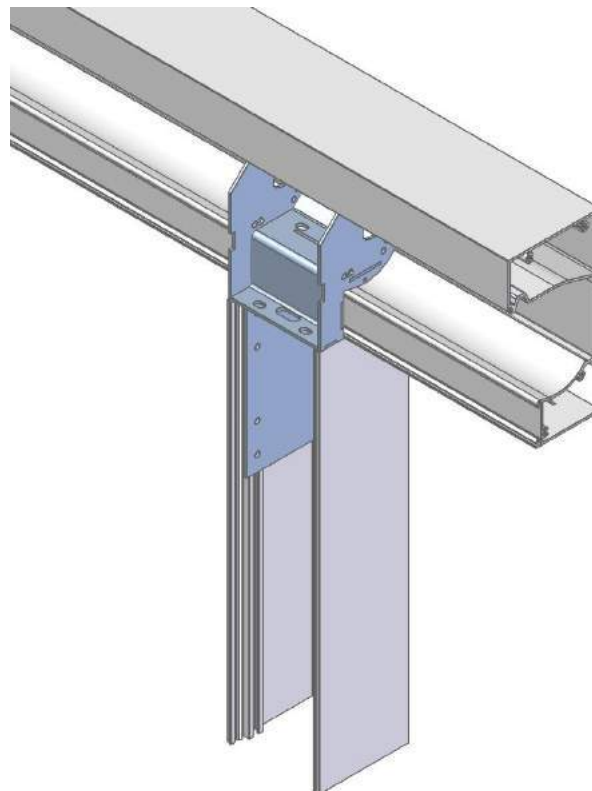
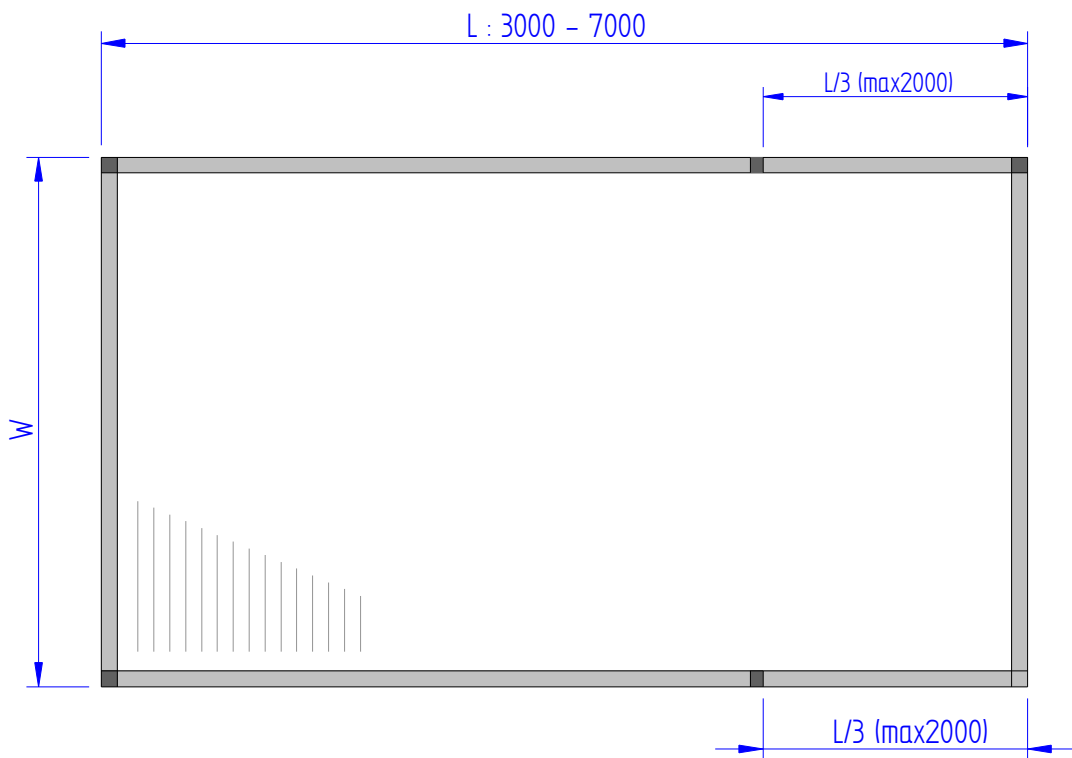

**Verbeter de spanning van de LED-Cover  
Improve the tension of the LED-Cover  
Améliorer l'accrochement du LED-cover**

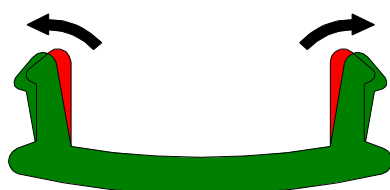
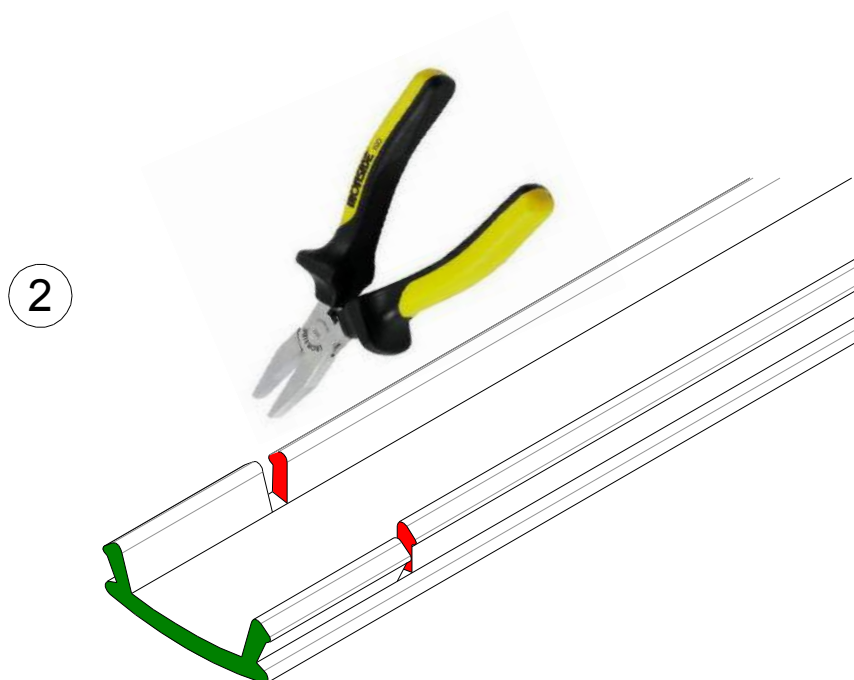
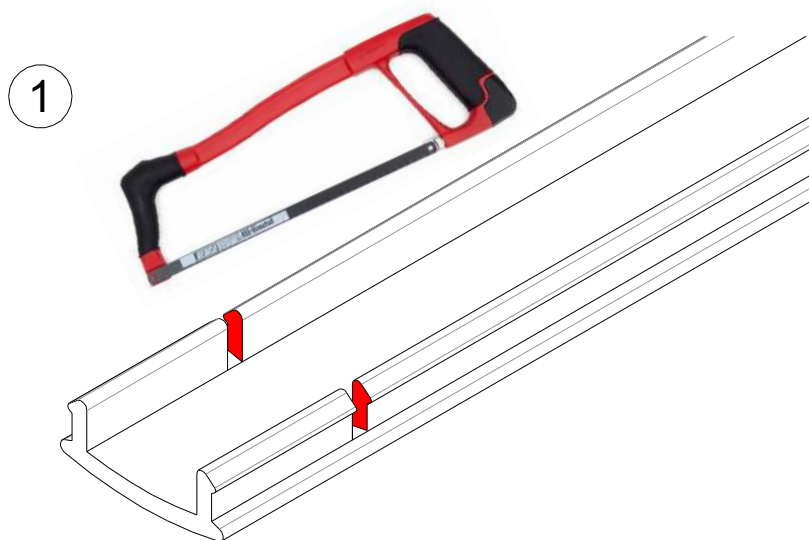

# Frame only

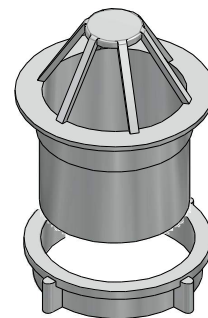

1900939

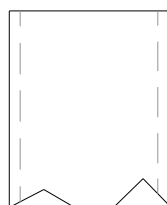
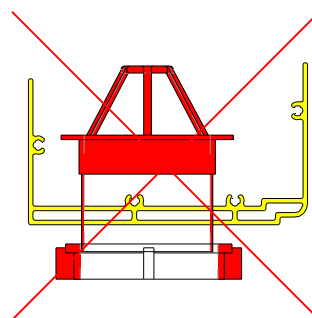
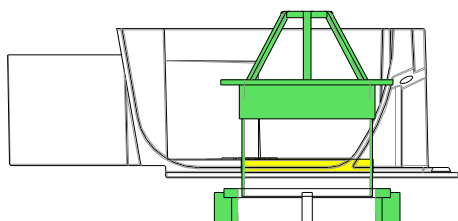
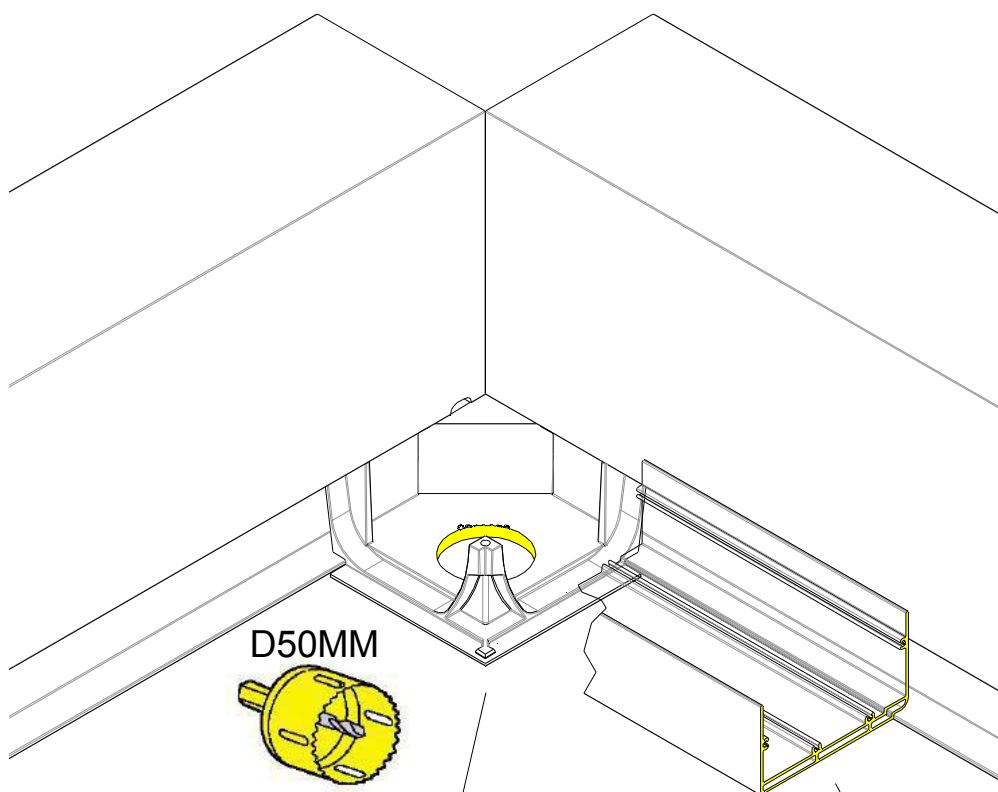

PVC  
D50



**Motorpositie**  
**Motorposition**  
**Position moteur**

**B200**

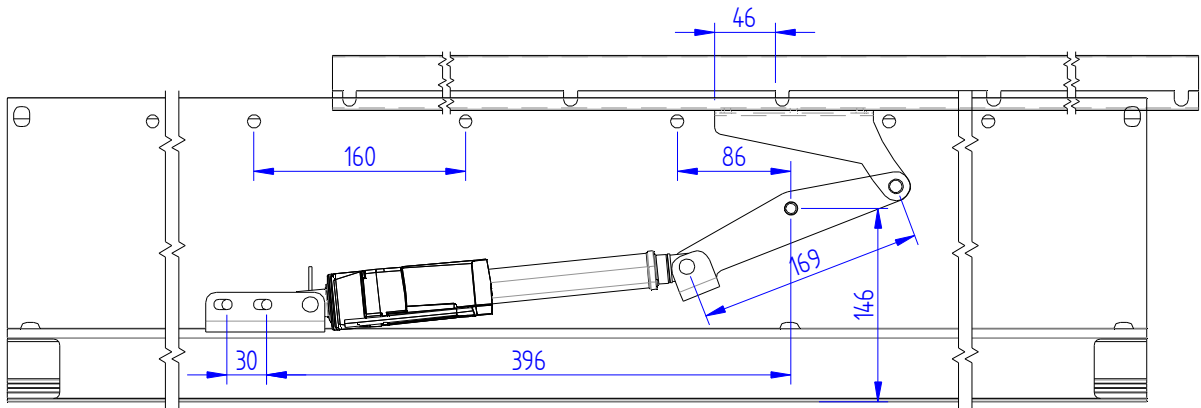

**B200XL**

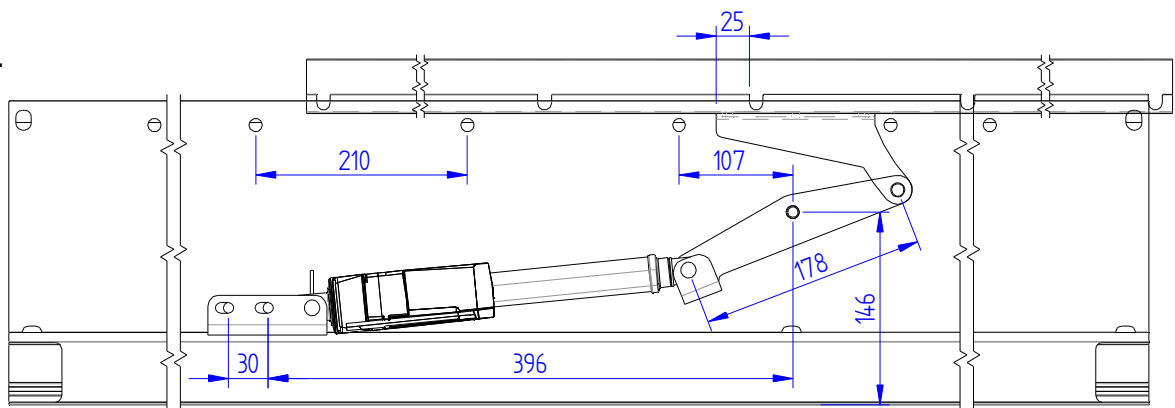

Lamellen vastzetten  
Fixing louvres  
Fixer des lames

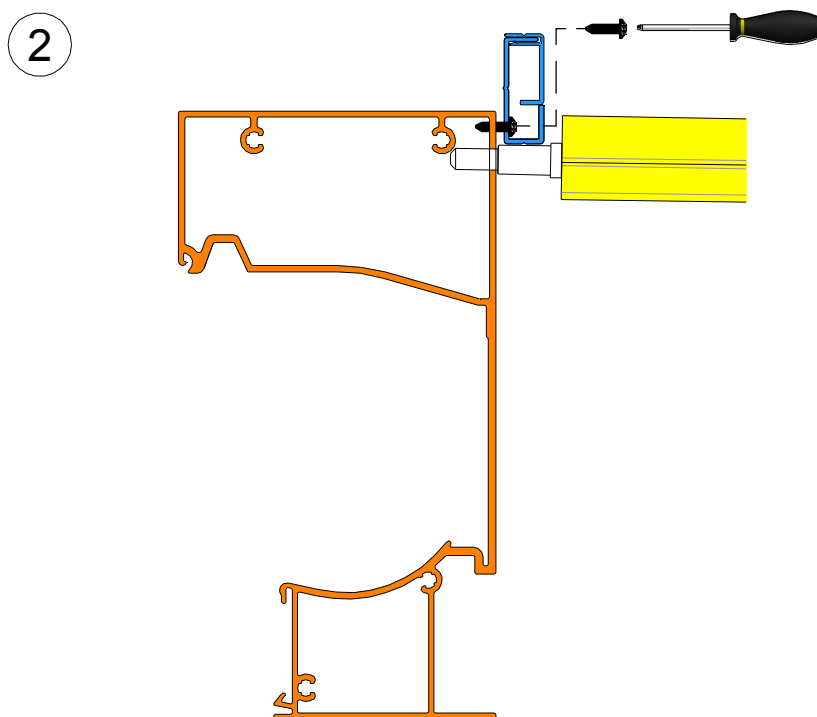
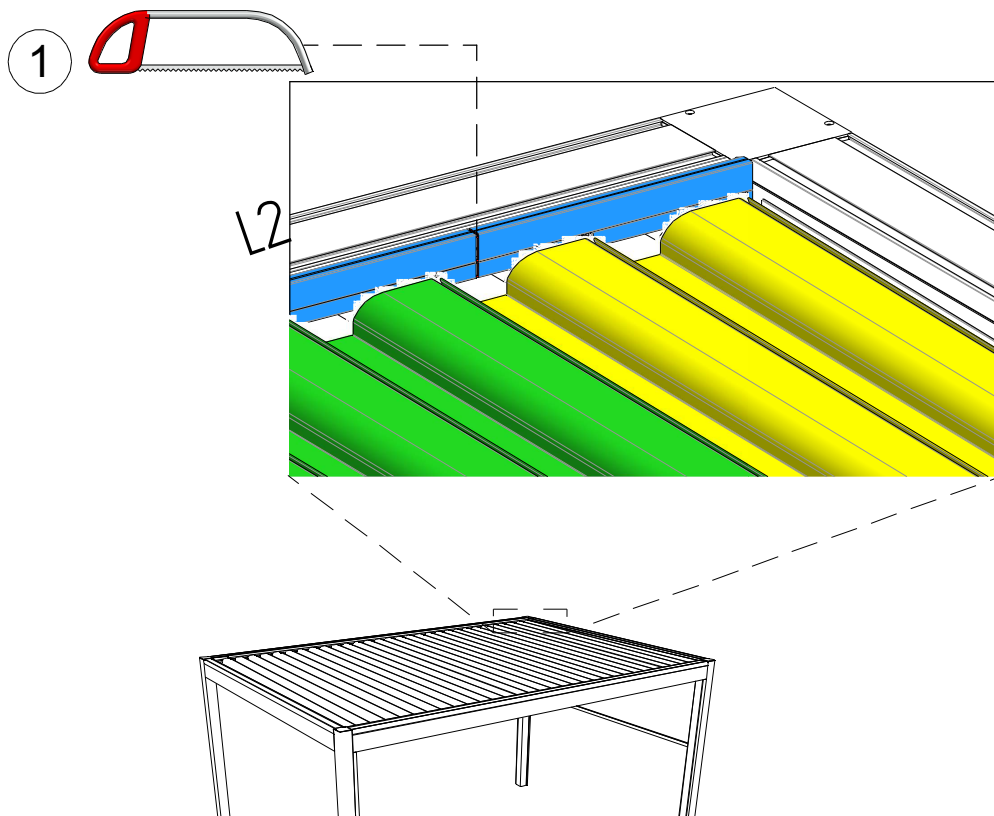

**Positie doekrolsteunen**  
**Position supports de tube d'enroulement**  
**Position rollertubesupports**

Screen/PVC zonder venster  
Screen/PVC without window  
Screen/PVC sans fenêtre

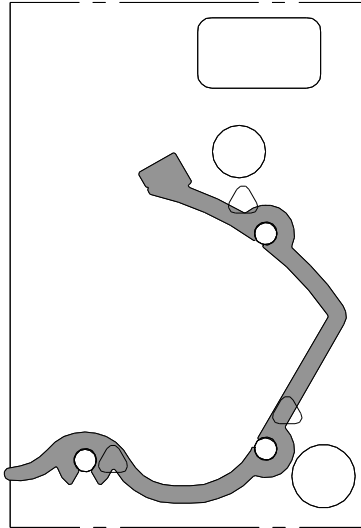

Screen/PVC met venster  
Screen/PVC with window  
Screen/PVC avec fenêtre

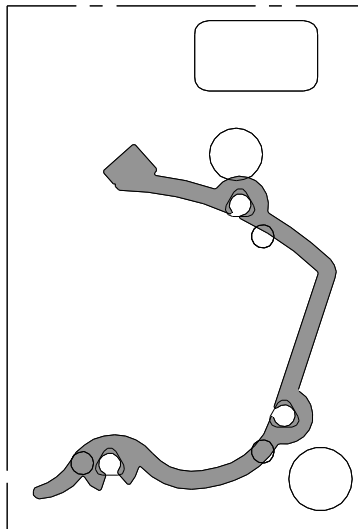

# "Lock Cover Mainhousing"

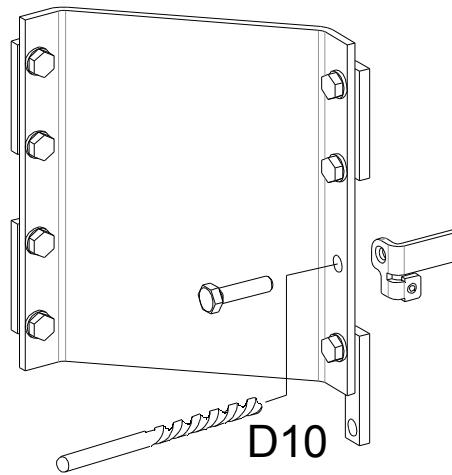
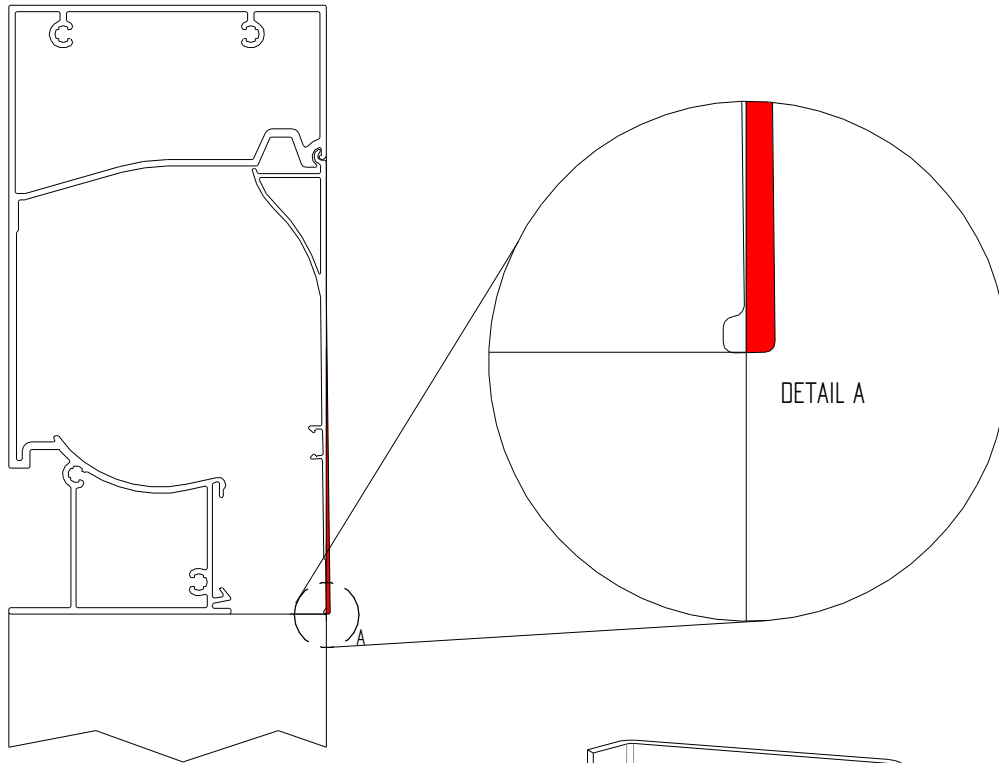

Verwarming  
 Heater  
 Chauffage  
 Heizung

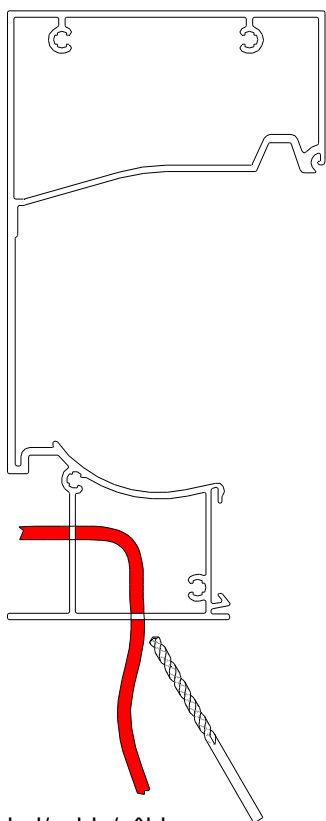
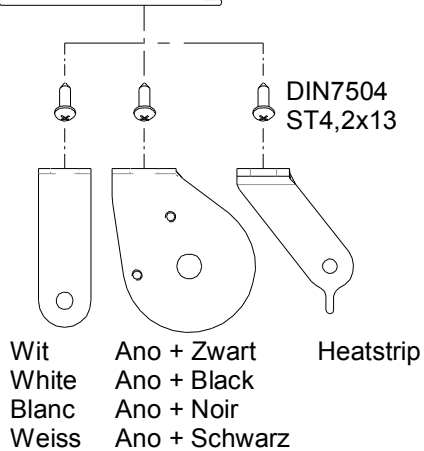
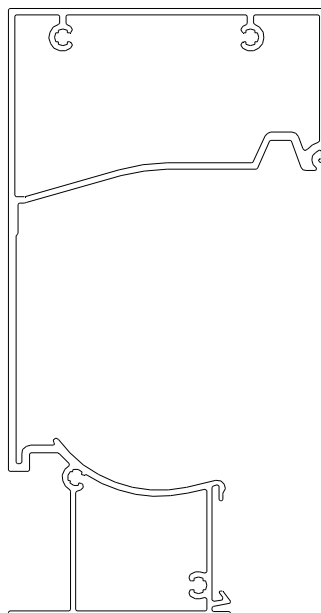

kabel/cable/câble

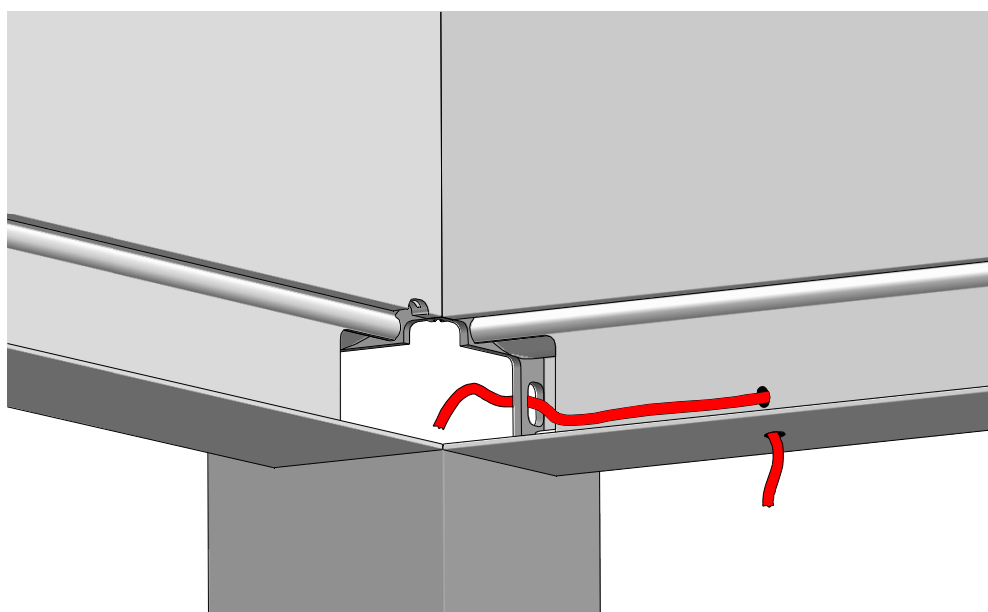

**Grondbevestiging**  
**groundfixation**  
**Fixation au sol**  
**Grundbefestigung**

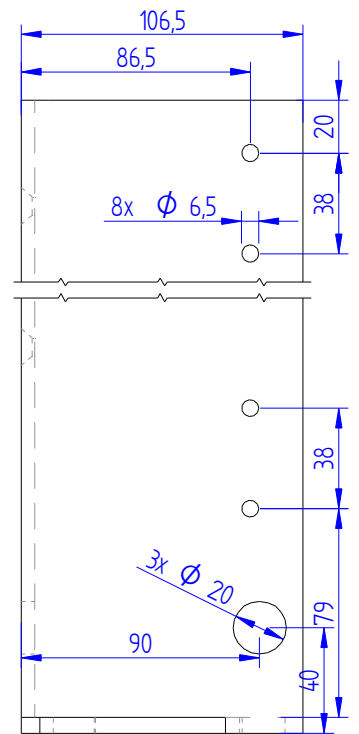
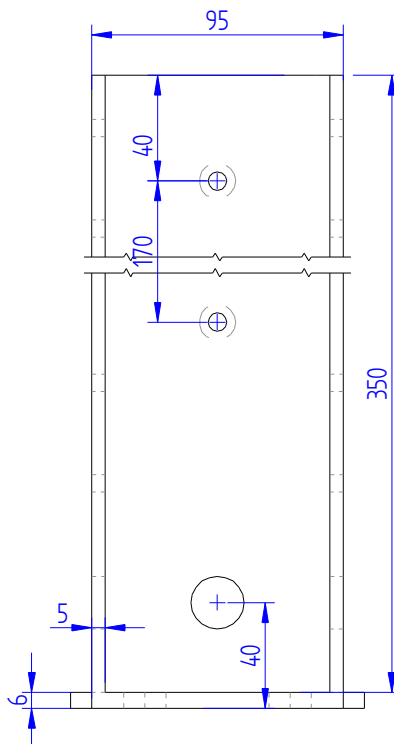
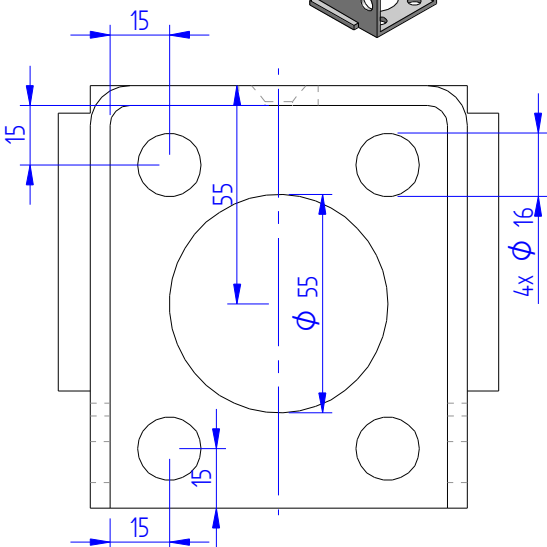
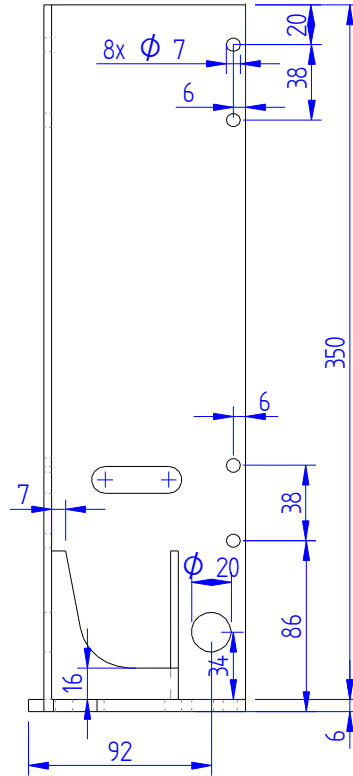
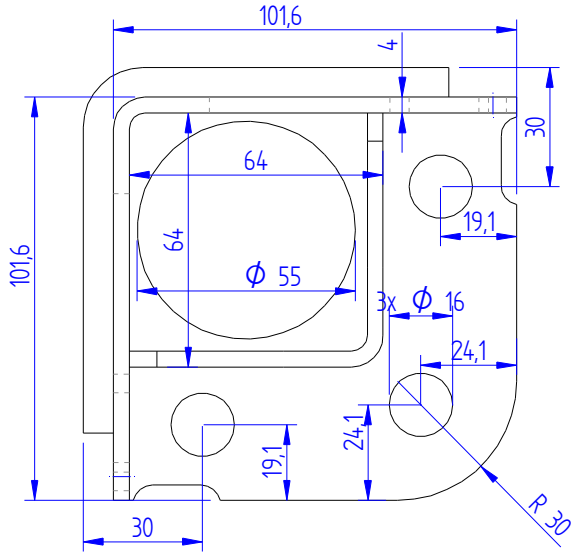

**Grondbevestiging**  
**groundfixation**  
**Fixation au sol**  
**Grundbefestigung**

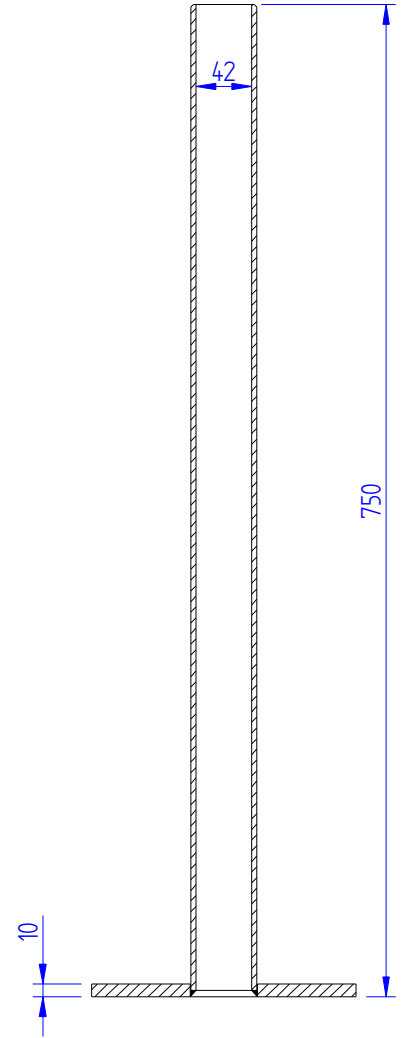
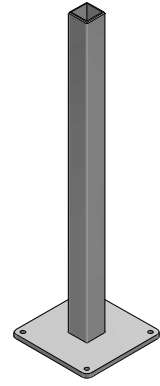
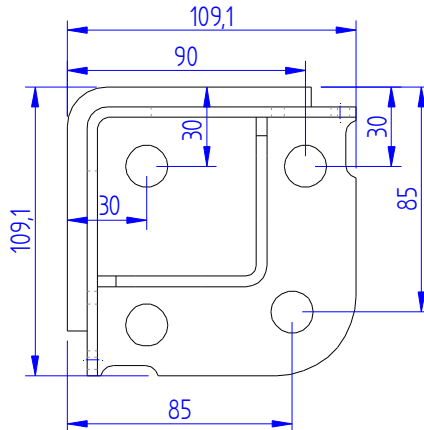
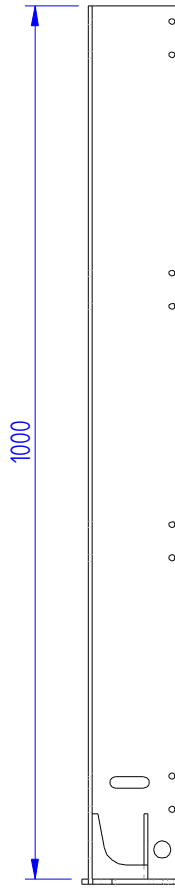
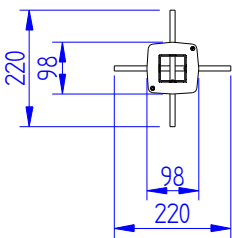
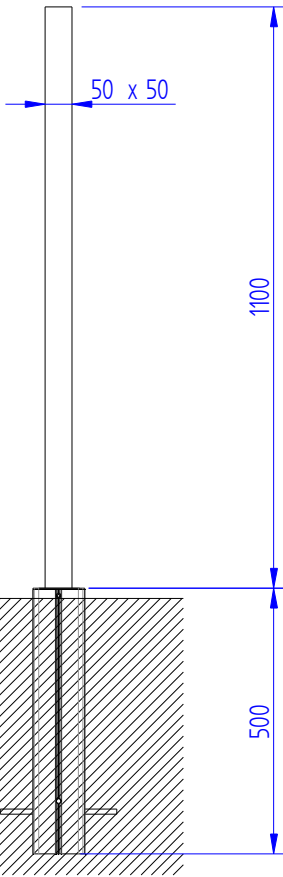
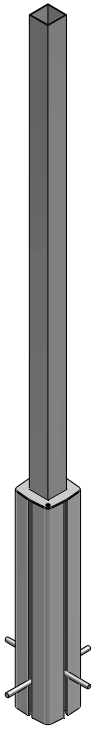

SECTION A-A

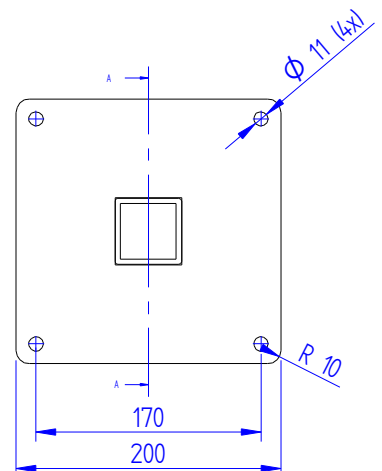

# Cover Mainhousing

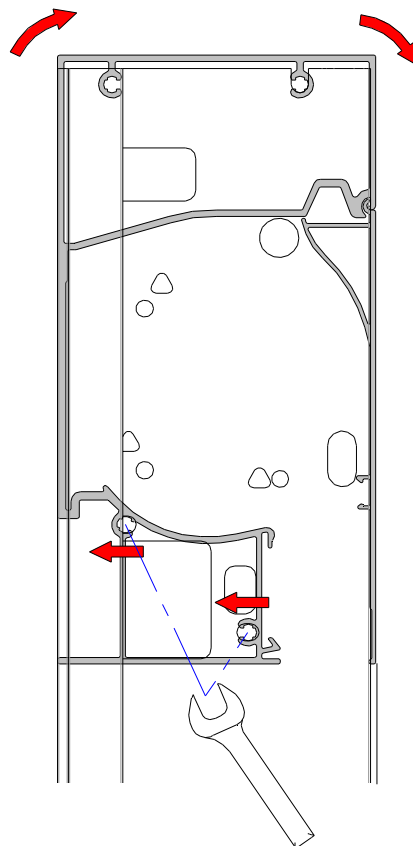
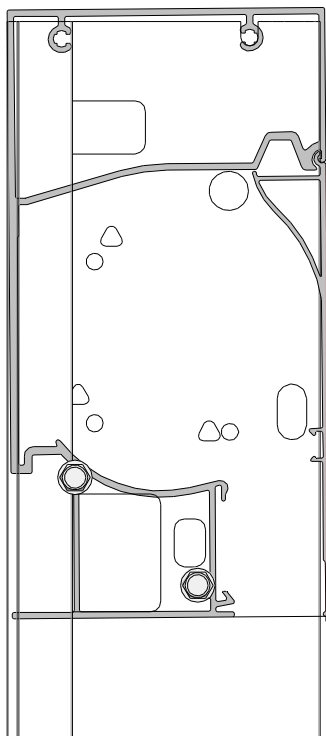
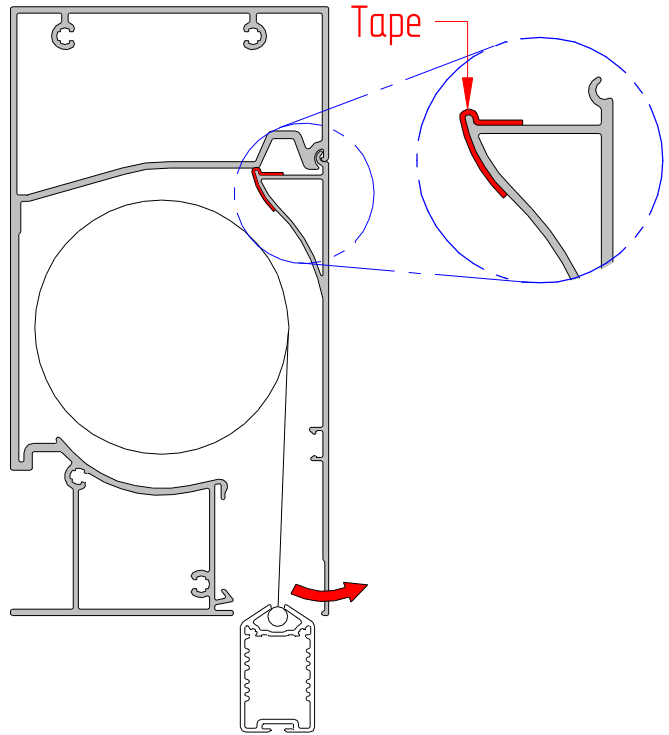
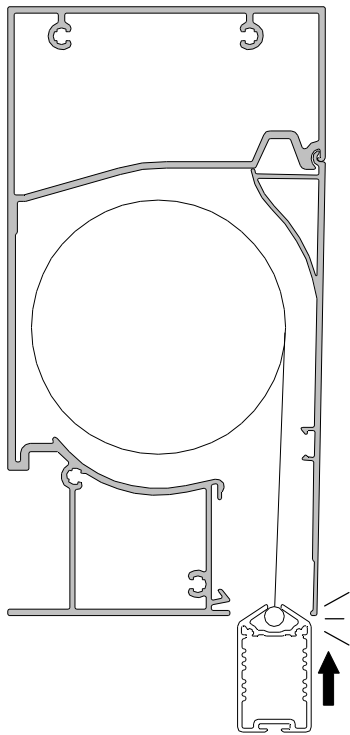



**Wateruitloop korte paal**  
**Water exit short pole**  
**Sortie d'eau poteau court**  
**Wasserabfluss kurzer pfosten**

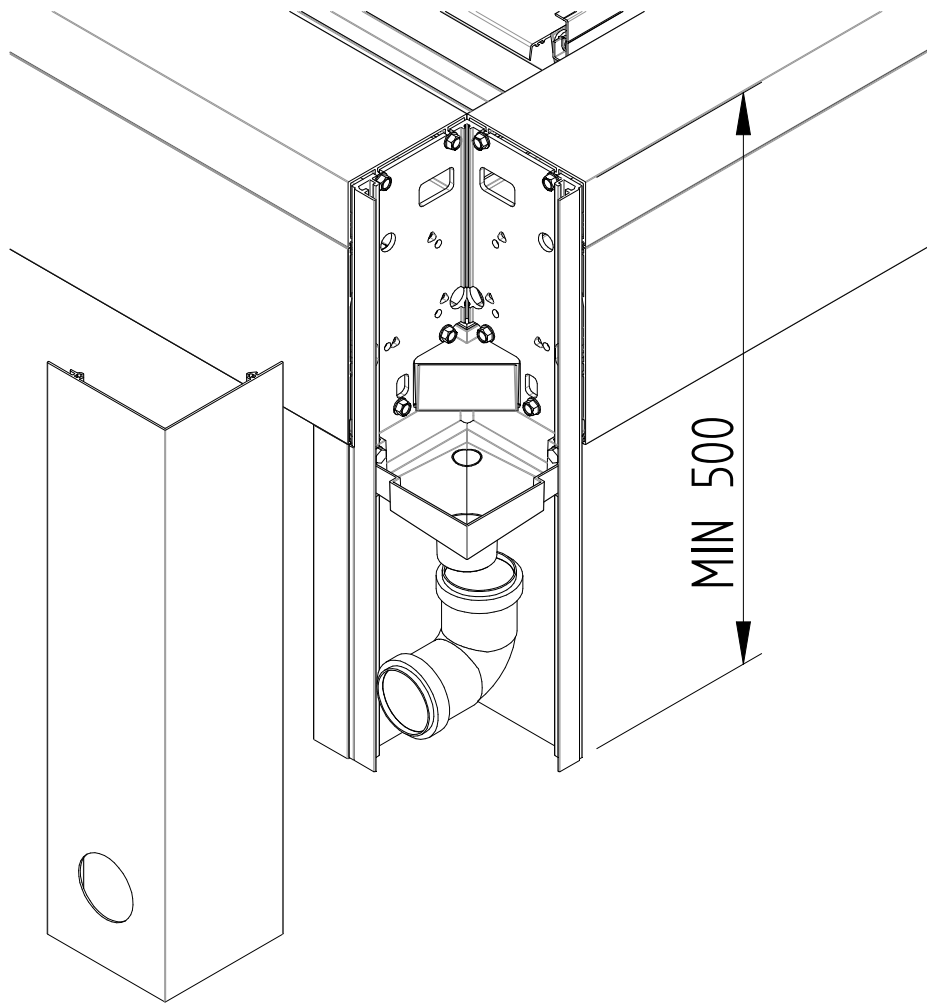

**Wateruitloop korte paal**  
**Water exit short pole**  
**Sortie d'eau poteau court**  
**Wasserabfluss kurzer pfosten**

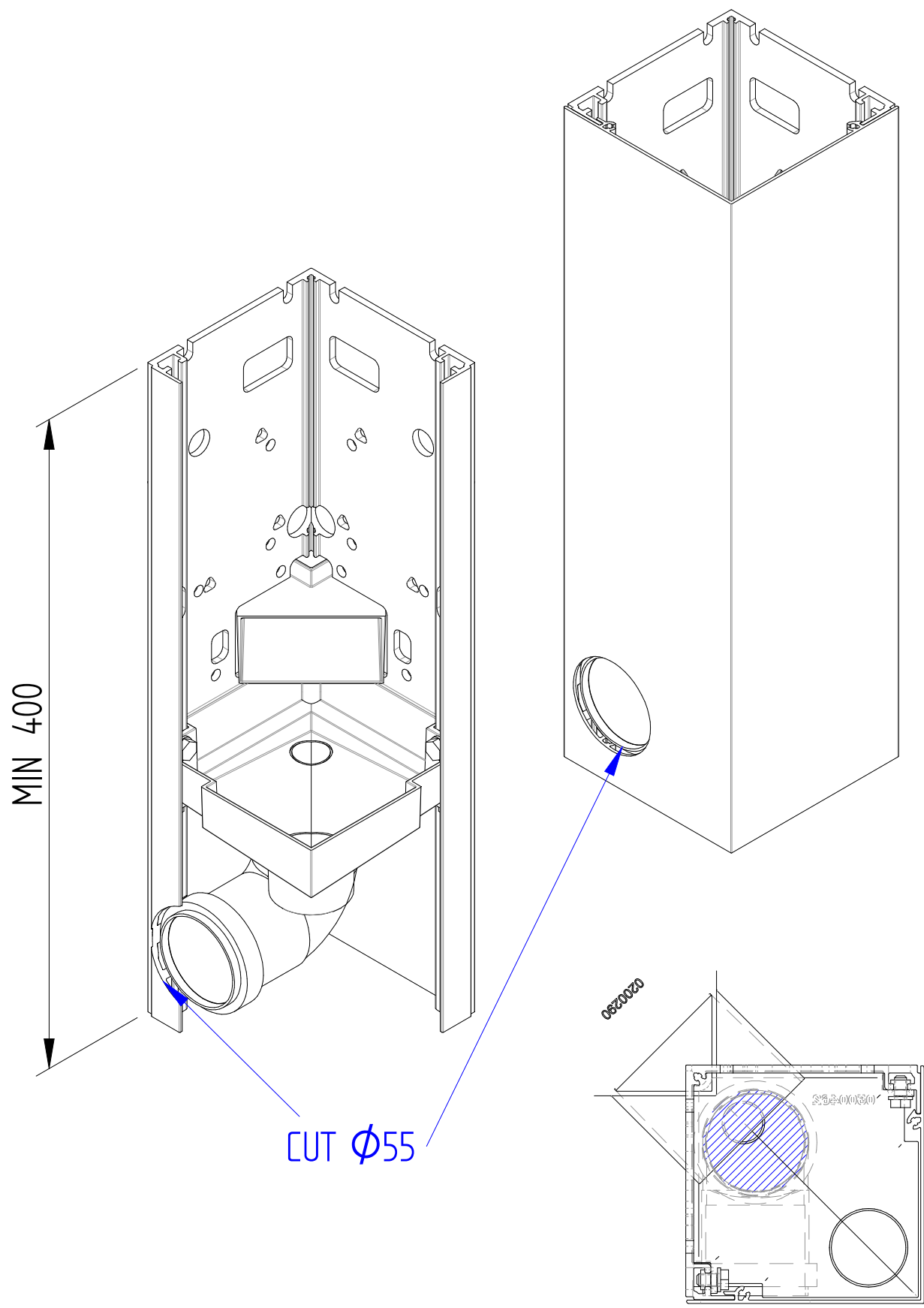

LED aan de regengoot - LED sur la gouttière - LED on the rain gutter - LED auf der Rinne

**OL-B200(XL)**

**1 Montage**

Zonder motor  
Sans moteur  
Without motor  
Ohne Motor

met motor  
Avec moteur  
With motor  
Mit Motor

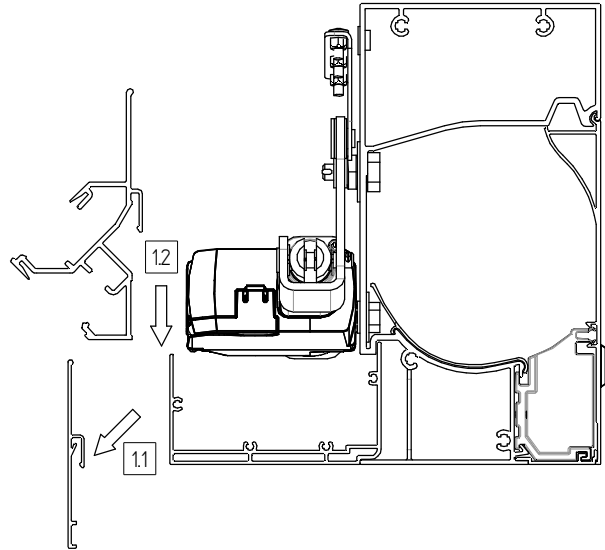
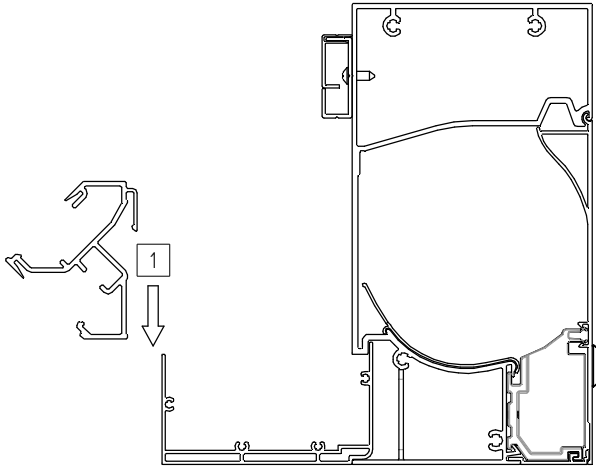

**2 Bekabeling  
Câblage  
Wiring  
Verkablung**

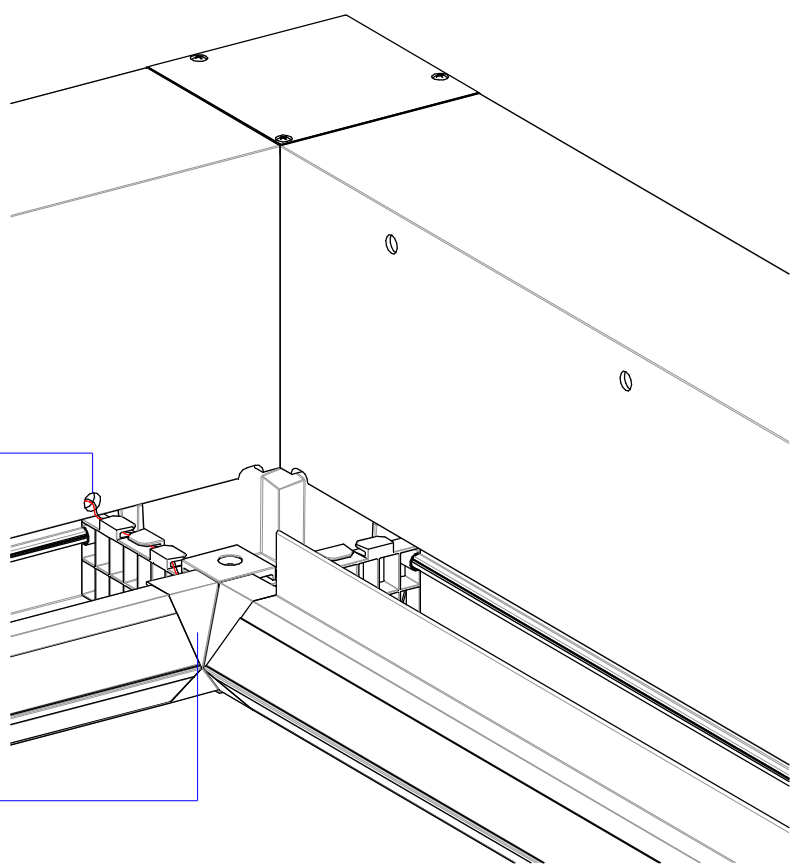
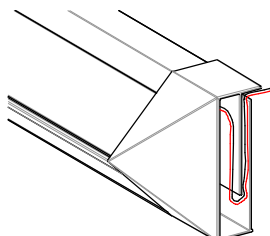
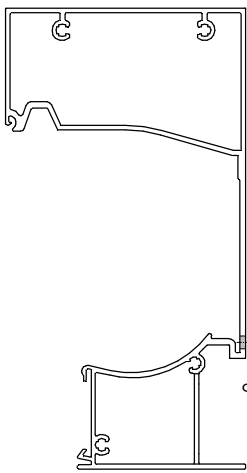

**3 Programmatie  
Programmation  
Programmierung**

1M1L - OL917  
LED - OL916

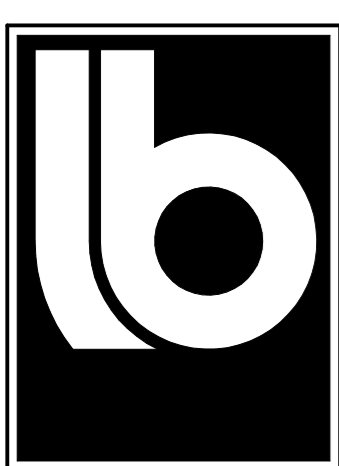

Dimbare witte LED's / LEDs blanches réglable à l'intensité / Dimmable White LEDs / Weiße dimmbare LED

ODL

### 1 Bekabeling Câblage Wiring Verkablung

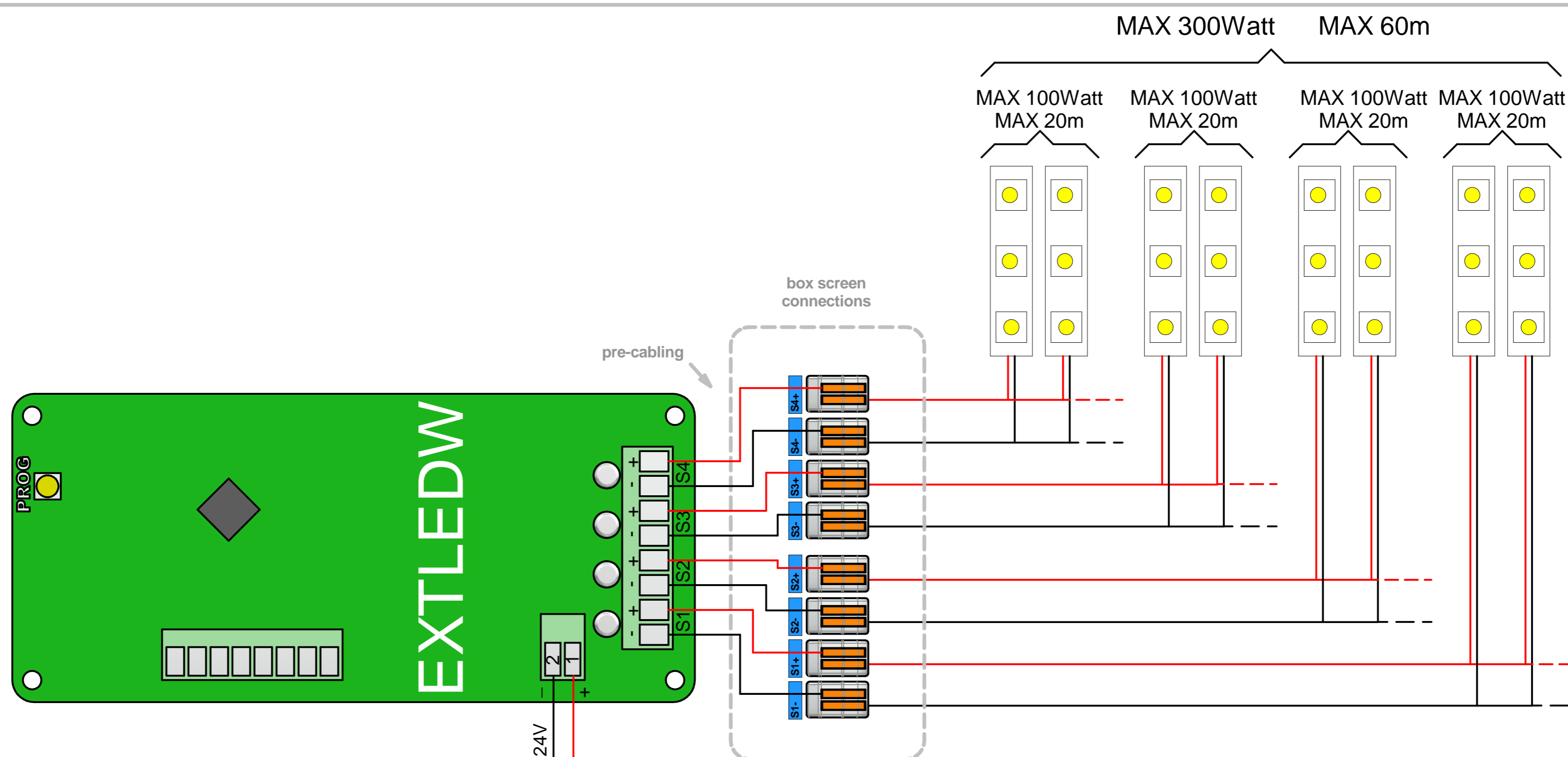

### 2 Programmatie Programmation Programmierung S1

2.1 x3  
Feedback

Druk minstens 2s op de PROG - Feedback op uitgang 1  
Appuyez plus de 2s sur le PROG - Feedback sur la sortie S1  
Press the PROG for at least 2s - Feedback on output S1  
Mindestens 2 Sek. auf der PROG-Taste drücken - Feedback auf S1

2.2 x3  
Feedback

Kies de gewenste uitgang - Feedback op S1-S2-S3-S4  
Sélectionnez la sortie souhaitée - Feedback sur S1-S2-S3-S4  
Select the desired output - Feedback on S1-S2-S3-S4  
Wählen Sie den gewünschten Ausgang Feedback auf S1 - S2 - S3 - S4

2.3

Bij een Telis 4/16, selecteer het gewenste kanaal  
Sur le Telis 4/16, sélectionnez le canal souhaité  
On a Telis 4/16, select the desired channel  
Bei Telis 4/16, wählen Sie den gewünschten Kanal

2.4

Druk op de PROG op de achterkant van de afstandsbediening  
Appuyez le PROG au dos de la télécommande  
Press the PROG on the back side of the remote control  
Drücken Sie auf der Hinterseite des Handsenders

### 3 Afstandsbediening Télécommande Remote control Handsender

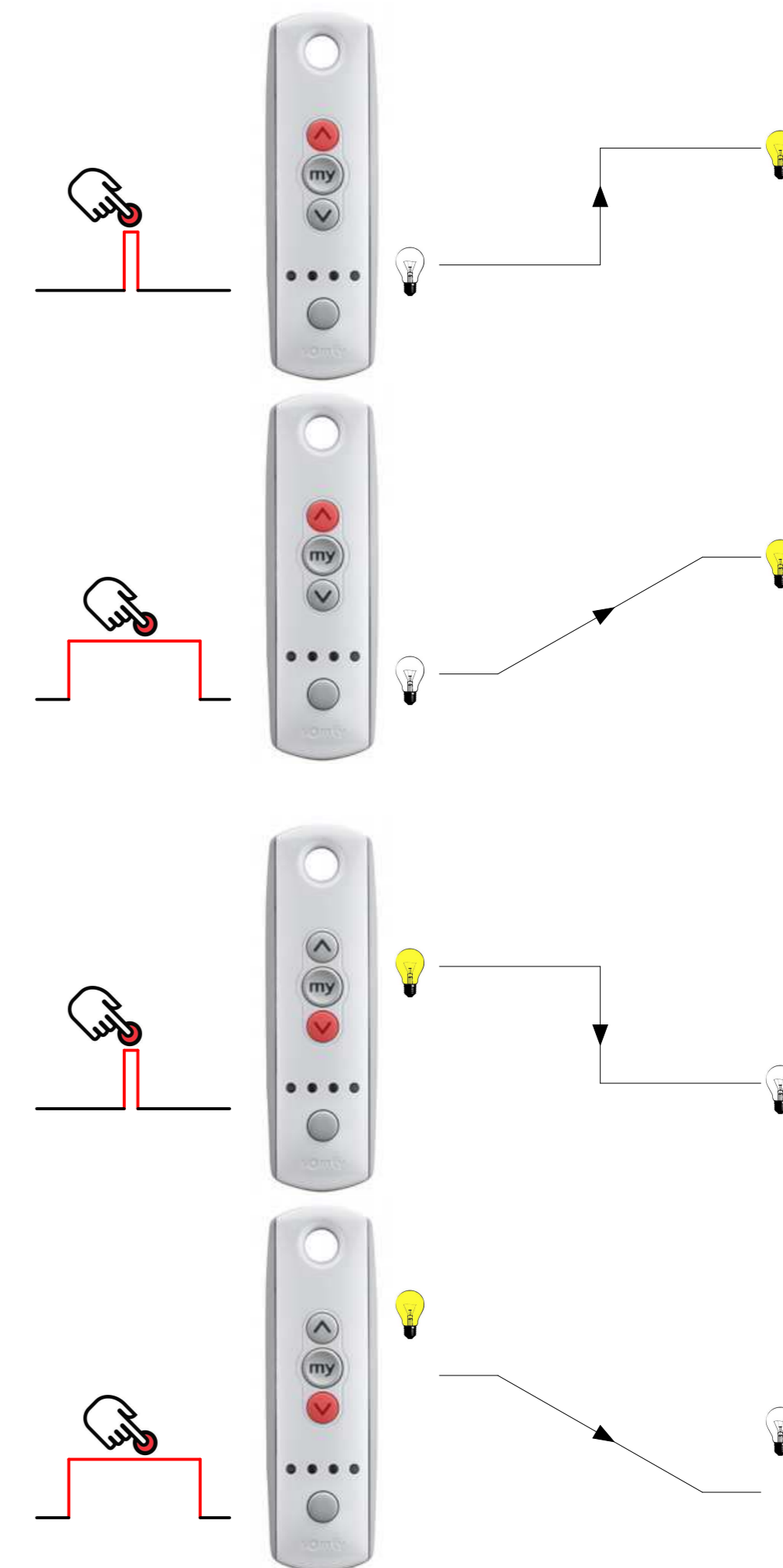

1M1L

OL-B200(XL)

**1 Bekabeling  
Câblage  
Wiring  
Verkablung**

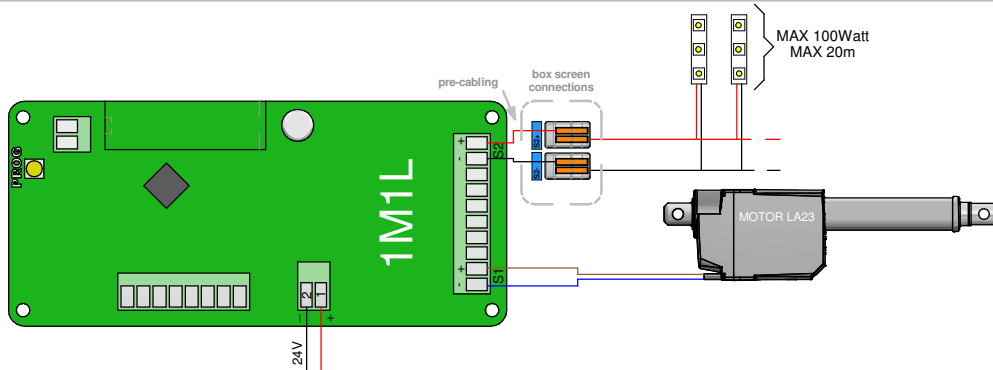

**2 Programmatie S1  
Programmation S1  
Programmierung S1**

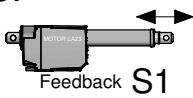

2.01

Druk minstens 2s op de PROG - Feedback op uitgang S1  
 Appuyez plus de 2s sur le PROG - Feedback sur la sortie S1  
 Press the PROG for at least 2s - Feedback on output S1  
 Mindestens 2 Sek. auf die PROG-Taste drücken - S1 blinkt

2.03

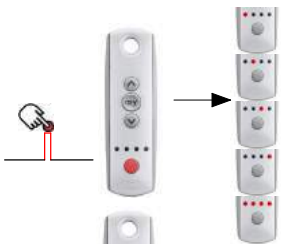

Bij een Telis 4/16, selecteer het gewenste kanaal  
 Sur le Telis 4/16, sélectionnez le canal souhaité  
 On a Telis 4/16, select the desired channel  
 Bei Telis 4/16, gewünschte Kanal wählen

2.04



Druk gelijktijdig op (^) en (v)  
 - Feedback op de gekozen uitgang  
 Appuyez simultanément sur (^) et (v)  
 - Feedback sur la sortie sélectionnée  
 Press simultaneously on (^) and (v)  
 - Feedback on the selected output  
 Gleichzeitig auf (^) auf (v) drücken und dabei

2.05

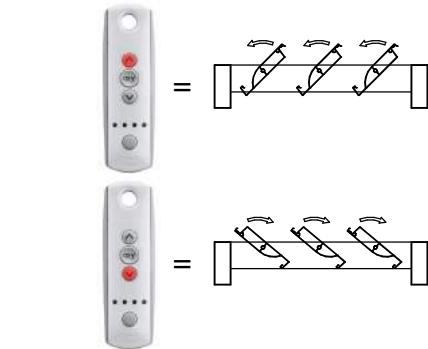

Controleer de richting: (^) = openen / (v) = sluiten  
 Vérifiez le sens: (^) = ouvrir / (v) = fermer  
 Check the direction: (^) = open / (v) = close  
 die Richtung kontrollieren: (^) = öffnen / (v) = schliessen

2.06

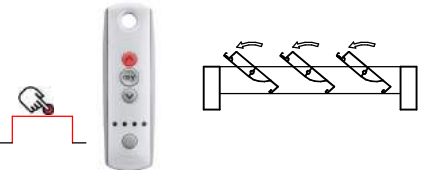

Open de pergola, blij drukken op de (^)  
 Ouvrez la pergola, appui maintenu (^)  
 Open the pergola, press and hold the (^)  
 Lamellen komplett öffnen (ständig auf (^) drücken)



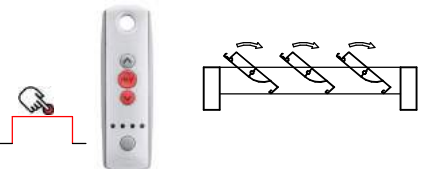





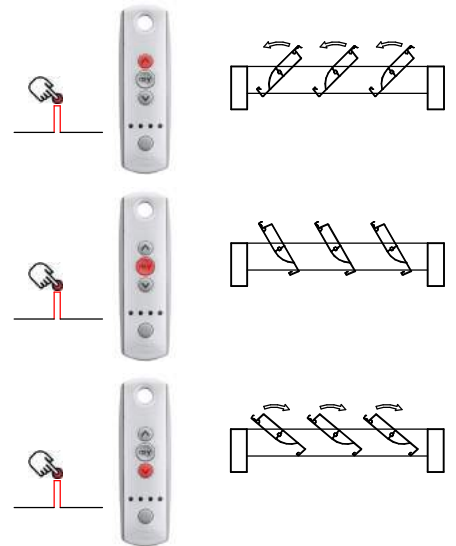



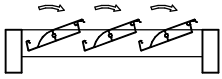

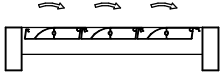

2.07



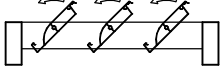

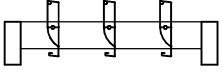

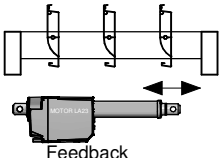

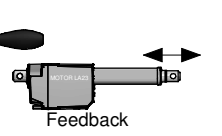
Bevestig de "maximaal open" positie. Druk gelijktijdig op (my) + (v)  
 Validez la position ouverture max en appuyant simultanément sur (my) + (v)  
 Confirm the "maximum open" position by pressing simultaneously on (my) + (v)  
 Position der "maximale Öffnung" der Lamellen bestätigen: gleichzeitig auf (My) und (V) drücken.

**2.15 Afstandsbediening  
Télécommande  
Remote control  
Handsender**

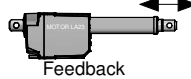

- 208    Stop de lamellen door op (my) te drukken  
Arrêtez le mouvement en appuyant sur (my)  
Stop the blades by pressing on the (my)  
Bewegung stoppen, Dafür auf die (My) Taste drücken
- 209    Sluit de Pergola, blijf drukken op de (v)  
Fermez la pergola, appui maintenu (v)  
Close the pergola, press and hold (v)  
Lamellen komplett schliessen, ständig auf (v) drücken
- 210    Bevestig de "maximaal gesloten" positie. Druk gelijktijdig op (^) + (my)  
Validez la position fermeture max en appuyant simultanément sur (^) + (my)  
Confirm the "maximum closed" position by pressing simultaneously on (^) + (my)  
Position des "maximale Schlusses" der Lamellen bestätigen: gleichzeitig auf "My" und (^) drücken.
- 211    Stop de lamellen door op (my) te drukken  
Arrêtez le mouvement en appuyant sur (my)  
Stop the blades by pressing on the (my)  
Bewegung stoppen, Dafür auf die (My) Taste drücken
- 212    Plaats de lamellen in de gewenste positie in geval van sneeuw (90°)  
Positionnez la pergola dans la position souhaitée en cas de neige (90°)  
Put the blades in the desired position, in case of snow (90°)  
Manuell die Lamellen senkrecht stellen (Schneeposition).
- 213    Bevestig de "sneeuw" positie. Druk minstens 2s op (my) \*Feedback\*  
Validez la position neige en appuyant (my) pendant plus de 2s \*Feedback\*  
Confirm the "snow" position by pressing the (my) for at least 2s \*Feedback\*  
Schneeposition bestätigen: mindestens 2 Sek. auf die "My"-Taste \*Feedback\*
- 214    Druk op de PROG op de achterkant van de afstandsbediening  
Appuyez le PROG au dos de la télécommande  
Press the PROG on the back side of the remote control  
Bestätigen auf der Hinterseite des Handsenders

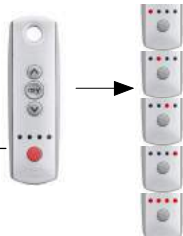
3 **Programmatie S2 = LED**  
**Programmation S2 = LED**  
**Programmierung S2 = LED**

- 31   Druk minstens 2s op de PROG - Feedback op uitgang S1  
Appuyez plus de 2s sur le PROG - Feedback sur la sortie S1  
Press the PROG for at least 2s - Feedback on output S1  
Mindestens 2 Sek. auf die PROG-Taste drücken - S1 blinkt
- 32   Druk kort op de PROG - Feedback op uitgang S2  
Appuyez brièvement sur le PROG - Feedback sur la sortie S2  
Briefly press the PROG - Feedback on output S2  
Kurz auf die PROG-Taste drücken - S2 blinkt
- 33   Bij een Telis 4/16, selecteer het gewenste kanaal  
Sur le Telis 4/16, sélectionnez le canal souhaitée  
On a Telis 4/16, select the desired channel  
Bei Telis 4/16, gewünschte Kanal wählen
- 34   Druk op de PROG op de achterkant van de afstandsbediening  
Appuyez le PROG au dos de la télécommande  
Press the PROG on the back side of the remote control  
Bestätigen auf der Hinterseite des Handsenders

3.5 **Afstandsbediening**  
**Télécommande**  
**Remote control**  
**Handsender**

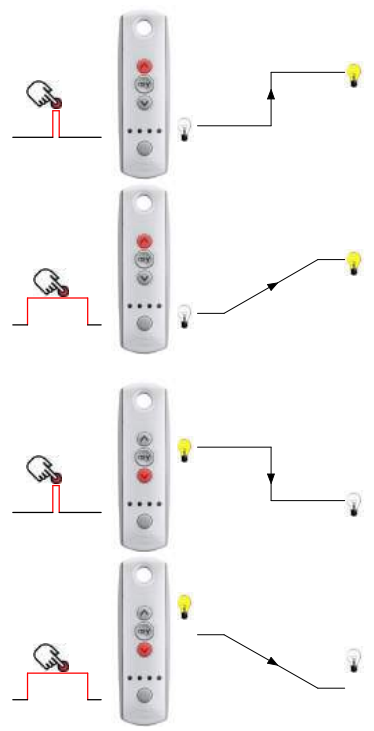

**1 Bekabeling  
Câblage  
Wiring  
Verkabelung**

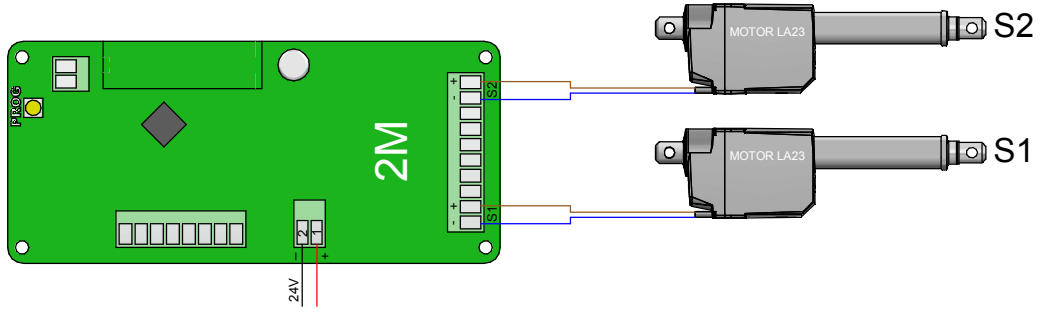

**2 Programmatie S1  
Programmation S1  
Programmierung S1**

2.01

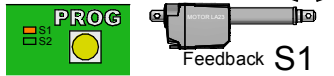

Druk minstens 2s op de PROG - Feedback op uitgang S1  
Appuyez plus de 2s sur le PROG - Feedback sur la sortie S1  
Press the PROG for at least 2s - Feedback on output S1  
Mindestens 2 Sek. auf die PROG-Taste drücken - S1 blinkt

**Programmatie S2  
Programmation S2**

2.01

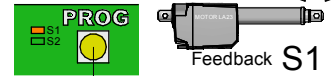

Druk minstens 2s op de PROG - Feedback op uitgang S1  
Appuyez plus de 2s sur le PROG - Feedback sur la sortie S1  
Press the PROG for at least 2s - Feedback on output S1  
Mindestens 2 Sek. auf die PROG-Taste drücken - S1 blinkt

2.02

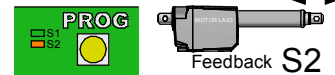

Druk kort op de PROG - Feedback op uitgang S2  
Appuyez brièvement sur le PROG - Feedback sur la sortie S2  
Briefly press the PROG - Feedback on output S2  
Kurz auf die PROG-Taste drücken - S1 blinkt

2.03

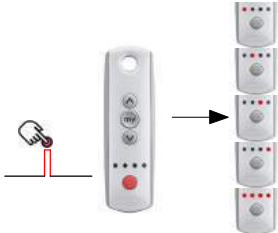

Bij een Telis 4/16, selecteer het gewenste kanaal  
Sur le Telis 4/16, sélectionnez le canal souhaité  
On a Telis 4/16, select the desired channel  
Bei Telis 4/16, gewünschte Kanal wählen

2.04

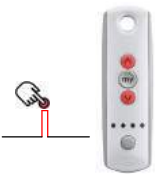

Druk gelijktijdig op (^) en (v) - Feedback op de gekozen uitgang  
Appuyez simultanément sur (^) et (v) - Feedback sur la sortie sélectionnée  
Press simultaneously on (^) and (v) - Feedback on the selected output  
Gleichzeitig auf (^) auf (v) drücken und dabei

2.05

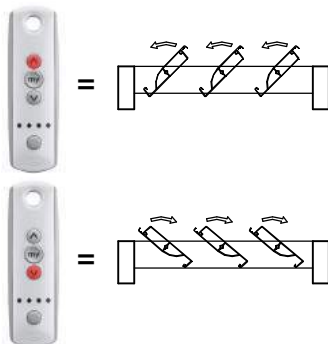

Controleer de richting: (^) = openen / (v) = sluiten  
Vérifiez le sens: (^) = ouvrir / (v) = fermer  
Check the direction: (^) = open / (v) = close  
die Richtung kontrollieren: (^) = öffnen / (v) = schliessen



Indien nodig, keer de richting om. Druk daarvoor minstens 5s op de (my) \*Feedback\* Controleer opnieuw de richting  
Si nécessaire, inversez le sens en appuyant plus de 5s sur (my) \*Feedback\*. Vérifiez à nouveau le sens  
If necessary, invert the direction by pressing the (my) for at least 5s \*Feedback\* Check again the direction  
Falls nötig, Richtung umdrehen. Dafür drücken Sie mindestens 5 Sek. auf die (My)Taste \*Feedback\*

2.06

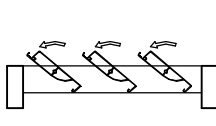

Open de pergola, blijf drukken op de (^)  
 Ouvrez la pergola, appui maintenu (^)  
 Open the pergola, press and hold the (^)  
 Lamellen komplett öffnen (ständig auf (^) drücken)

2.07

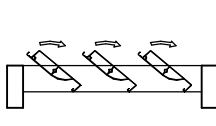

Bevestig de "maximaal open" positie. Druk gelijktijdig op (my) + (v)  
 Validez la position ouverture max en appuyant simultanément sur (my) + (v)  
 Confirm the "maximum open" position by pressing simultaneously on (my) + (v)  
 Position der "maximale Öffnung" der Lamellen bestätigen: gleichzeitig auf (My) und (V) drücken.

2.08

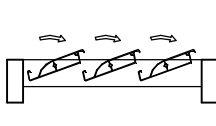

Stop de lamellen door op (my) te drukken  
 Arrêtez le mouvement en appuyant sur (my)  
 Stop the blades by pressing on the (my)  
 Bewegung stoppen, Dafür auf die (My) Taste drücken

2.09

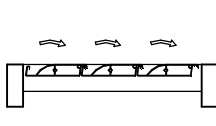

Sluit de Pergola, blijf drukken op de (v)  
 Fermez la pergola, appui maintenu (v)  
 Close the pergola, press and hold (v)  
 Lamellen komplett schliessen, ständig auf (v) drücken

2.10

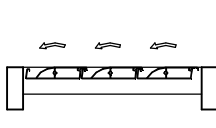

Bevestig de "maximaal gesloten" positie. Druk gelijktijdig op (^) + (my)  
 Validez la position fermeture max en appuyant simultanément sur (^) + (my)  
 Confirm the "maximum closed" position by pressing simultaneously on (^) + (my)  
 Position des "maximale Schlusses" der Lamellen bestätigen: gleichzeitig auf "My" und (^) drücken.

2.11

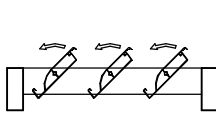
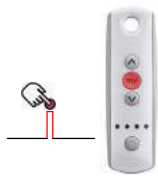

Stop de lamellen door op (my) te drukken  
 Arrêtez le mouvement en appuyant sur (my)  
 Stop the blades by pressing on the (my)  
 Bewegung stoppen, Dafür auf die (My) Taste drücken

2.12

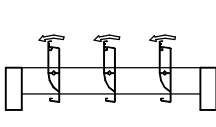

Plaats de lamellen in de gewenste positie in geval van sneeuw (90°)  
 Positionnez la pergola dans la position souhaitée en cas de neige (90°)  
 Put the blades in the desired position, in case of snow (90°)  
 Manuell die Lamellen senkrecht stellen (Schneeposition).

2.13

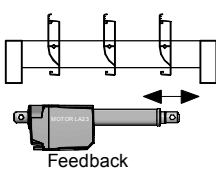
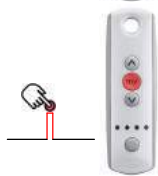

Bevestig de "sneeuw" positie. Druk minstens 2s op (my) \*Feedback\*  
 Validez la position neige en appuyant (my) pendant plus de 2s \*Feedback\*  
 Confirm the "snow" position by pressing the (my) for at least 2s \*Feedback\*  
 Schneeposition bestätigen: mindestens 2 Sek. auf die "My"-Taste "Feedback"

2.14

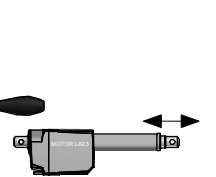
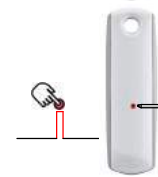

Druk op de PROG op de achterkant van de afstandsbediening  
 Appuyez le PROG au dos de la télécommande  
 Press the PROG on the back side of the remote control  
 Bestätigen auf der Hinterseite des Handsenders

3

### Afstandsbediening Télécommande Remote control Handsender

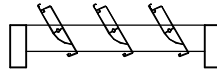
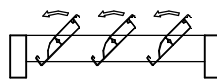





Antenne

OL-B200(XL)

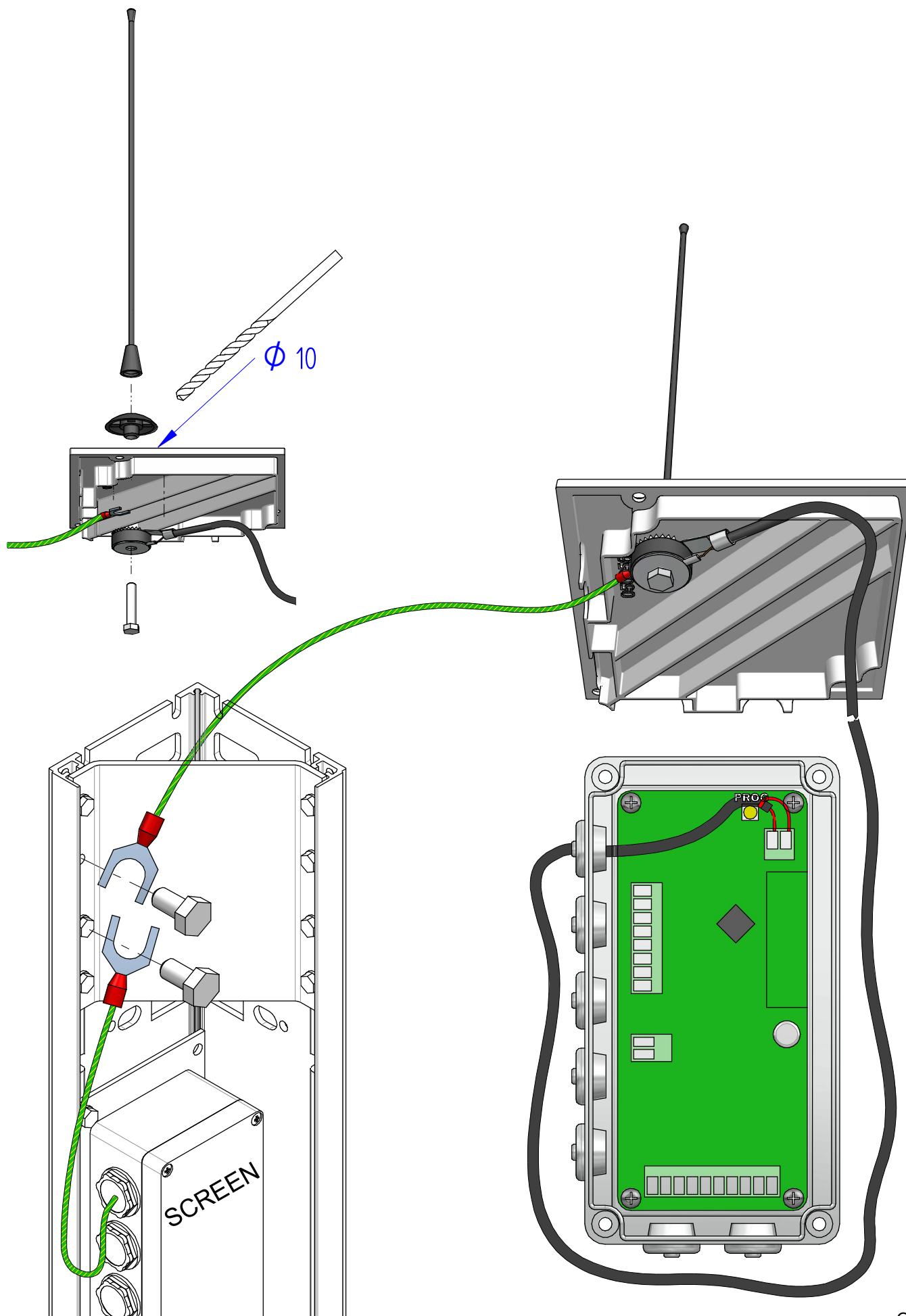

### B150(XL) RAIN/SNOWSENSOR

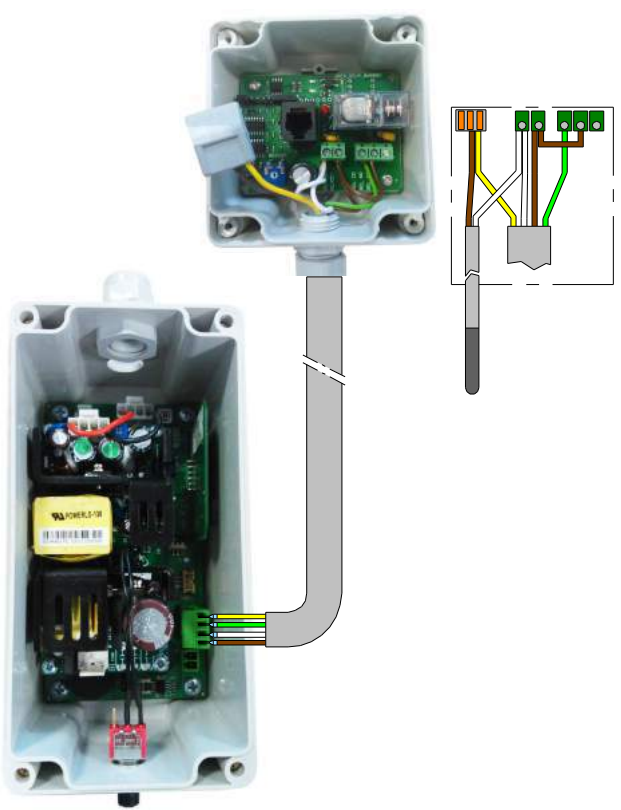

### B150(XL) RAINSENSOR

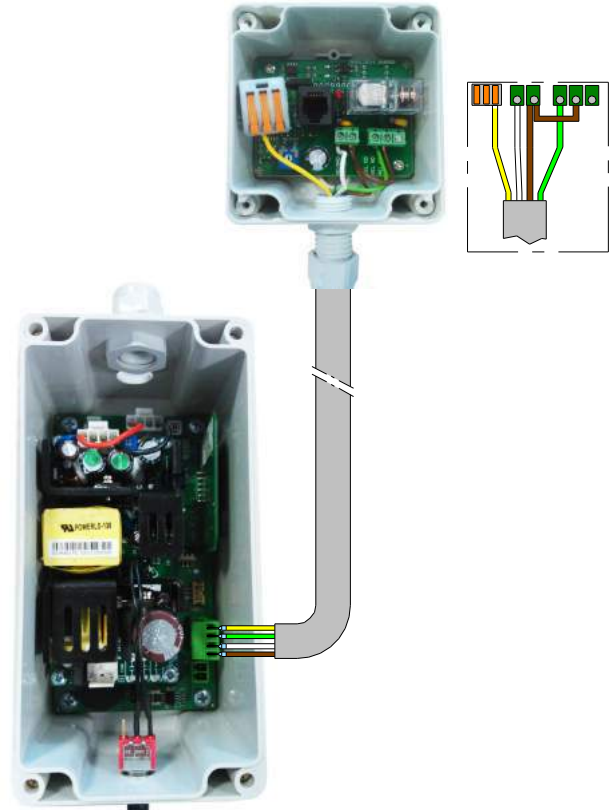

### B200(XL) RAIN/SNOWSENSOR

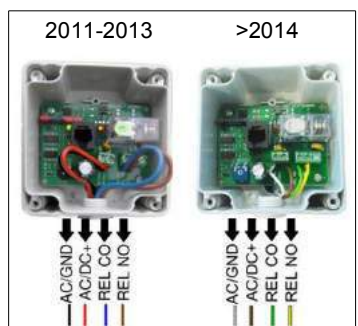
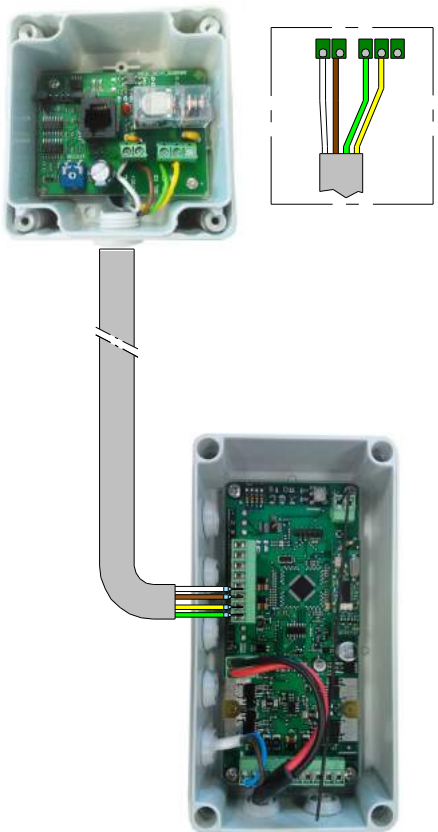

### B150(XL) RAIN/SNOWSENSOR

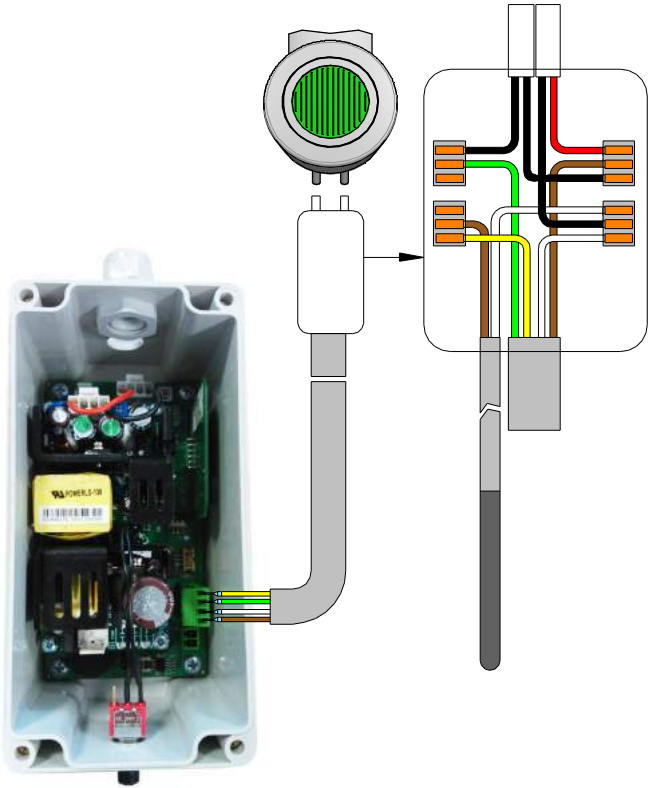

### B150(XL) RAINSENSOR

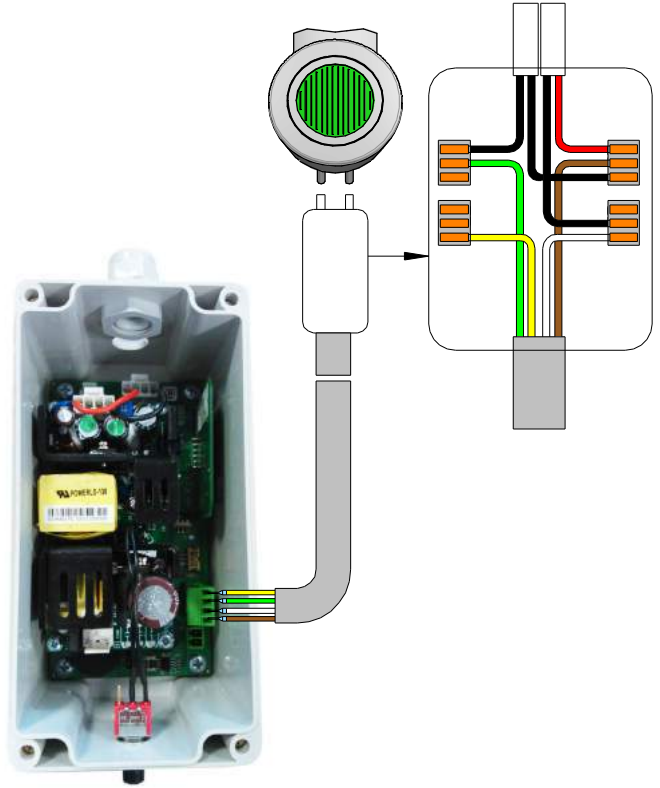

### B200(XL) RAIN/SNOWSENSOR

